

RADIO BROADCAST

Vol. 7, No. 4



August, 1925

From Figures to Fame

Professor Louis Alan Hazeltine Finds that the Algebraic Unknown Quantity, X, Equals Fame, Fortune, and the Neutrodyne

BY MYRA MAY

SELDOM, if ever, would any one select algebra as a sure road to fortune. While plumbing, banking, advertising, physics and every kind of concentration are glaringly depicted as a part of the curriculum of most correspondence school courses, it is exceedingly unlikely that these confident advertisers would indicate algebra as the one path through which one might attain to Fame and Fortune—that visionary goal of one's dreams. But it has been demonstrated that algebra and Fame and Fortune are somewhat synonymous and that one gains experience from the one branch of mathematics that helps to solve the intricate problems of the higher branch. And so the unknown quantity, X, may, after all, be the Fame and Fortune of your dreams as well as the solution to your involved algebraic equation. It is seldom that one gains Fame and Fortune through the direct application of mathematics, however, and, student or scholar, he is fortunate, indeed, who, having solved his algebraic problem, finds that the X, literally spells Fortune itself. Such was the case with Louis Alan Hazeltine, inventor of the "neutrodyne" circuit.

If someone were to ask you why radio interested you, you might reply that you liked to try for distance, or that you enjoyed the enter-



PROFESSOR LOUIS ALAN HAZELTINE

Inventor of the neutrodyne circuit, embodied in thousands of receivers used all over this country and abroad. Mr. Hazeltine is head of the Department of Electrical Engineering at Stevens Institute of Technology at Hoboken, New Jersey, and is here shown using a wavemeter in his laboratory

tainment that a full program affords, or you might, like Professor Hazeltine, answer that it is the science of radio which interests you. Professor Hazeltine explains that it was the opportunity to work out mathematical problems that first led him to experiment with radio. He has never been especially interested in either the programs of broadcasting stations or in attempts to receive long distances. He has been concerned with little but the scientific side of wireless. It is characteristic of the man that he did not have a neutrodyne set himself until several years after he had worked out the fundamental theory mathematically and had made application for his patents.

PROFESSOR HAZELTINE LIKES MATHEMATICS

MATHEMATICS has always been a favorite of mine," he says. "At school I once received a prize for my good work and my highest grades were always in mathematics. By chance, I graduated first in my class, but that was only by chance, for I had consistently held second place until the leader went to live in another city. From a high school in New London, Connecticut, I transferred to Stevens Institute of Technology where in 1906 I graduated with the degree of Mechanical Engineer."

Professor Hazeltine is too modest to tell that he finished his school and college course in twelve years instead of the sixteen most of us give to it. He prefers to let people find that out for themselves.

"I remember," he reminisces, "when I was a little boy I saw my uncle working out some algebraic calculations: he explained that he made those queer hieroglyphics just for amusement. I marvelled at such a pastime when there were such sports as baseball and swimming to claim spare hours. I had no premonition that some day I, too, would devote my leisure to the same queer hieroglyphics.

"When I entered Stevens Institute I did not know what branch of engineering I wanted to take up, but I did know that I had a prejudice against electrical engineering. Nevertheless, near the end of my course I began to feel that the performance of electrical apparatus could be predetermined more accurately than that of mechanical. It was this feeling that led me to change my field to electrical engineering in spite of my former prejudices, and later, it was this same feeling that led me to specialize in radio."

After graduating from Stevens Institute,

Professor Hazeltine entered the testing department of the General Electric Company in Schenectady where he received a practical training. This was his only venture along the highroad of business, for the following year he was offered a position as assistant in the Department of Electrical Engineering at Stevens Institute and he has remained at that college ever since.

WHY HAZELTINE SPECIALIZED IN RADIO

I WAS fortunate in my surroundings at Stevens," says Professor Hazeltine, "for my work covered all branches of electrical engineering and the head of the department, Professor Albert F. Ganz, was always aiding and inspiring my further progress. During this period I specialized in one branch of electrical engineering after another, and prepared much of the material for presentation to my classes. It was in this manner that I gradually developed a text on electrical engineering, which has but recently been published.

"Professor Ganz was the foremost authority in this country on the subject of electrolytic corrosion of underground structures by stray electric current, particularly from electric railways. At times I assisted him in this work and for several years after his death I was associated with the firm of Albert F. Ganz, Incorporated, which continued his professional work in electrolysis."

During the winter of 1914-1915, the well-known radio experimenter, E. H. Armstrong, wrote a paper, presented before the Institute of Radio Engineers, on the fundamentals of the three-electrode vacuum tube and then in a subsequent paper described in detail the tube's capabilities for oscillating which he had discovered. The young instructor at Stevens, who had always been partial to any branch of mathematical science, found a new and delightful field before him. Here at last was a real opportunity to apply mathematical analysis.

THEORY PRECEDES PRACTISE

LONG before Professor Hazeltine had one of the desired vacuum tubes he began a theoretical study of its operation, and it was in this manner that he worked out the theoretical requisite for the production of oscillations. Not until then did he obtain a vacuum tube (then known as an audion) to trace its characteristic curve. On the basis of that information he designed his circuit, wired it, and immediately obtained the anticipated result.

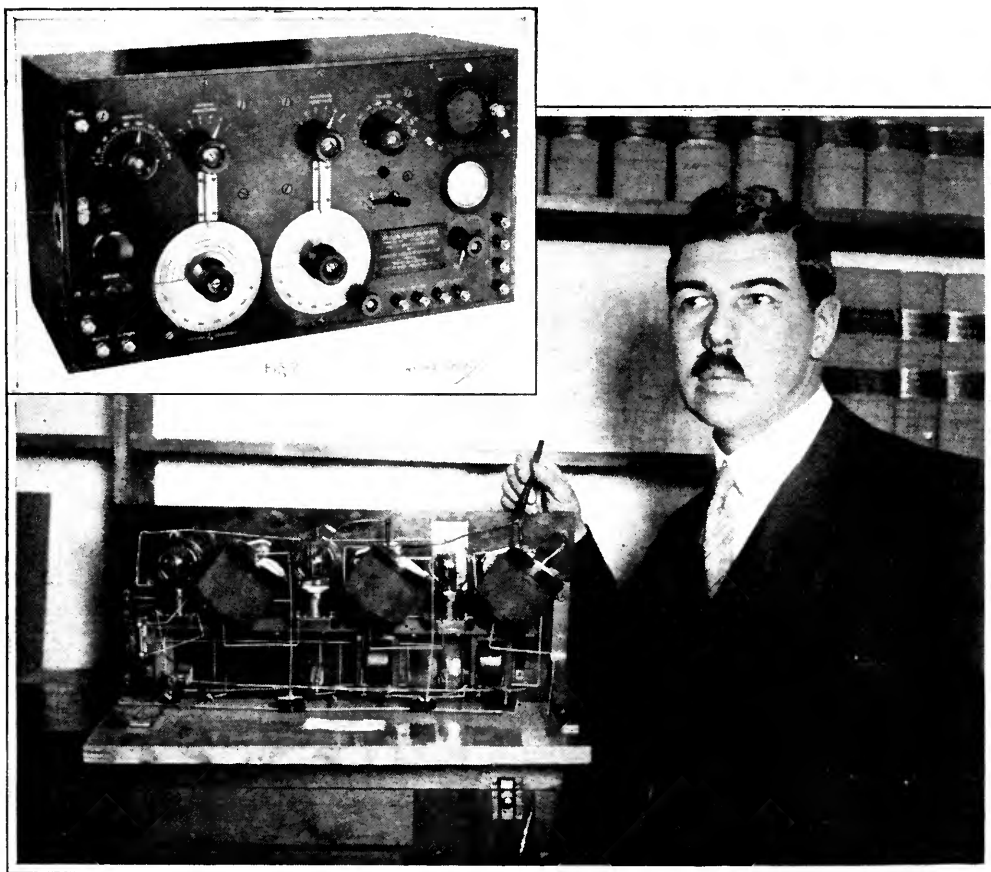

TWO RECEIVERS

Designed by Professor Hazel-tine. The one in the insert was designed for the Navy Department during the war and is known officially as the SE 1420. It was while he was developing this receiver that the idea for the neutrodyne circuit was partially evolved. The larger photograph shows Mr. Hazel-tine and one of his models of the neutrodyne

In spite of this remarkable performance, Professor Hazel-tine continued his theoretical studies coupled with experimental verifications for the next two years, and it was not until 1917 that he felt that his work was in sufficiently perfect form to give it to the world. His paper on "Oscillating Audion Circuits" which gave the results of his investigations was read before the Institute of Radio Engineers. This was the first time that a general and yet a simple mathematical method for the treatment of oscillating audion circuits had been given. It was in this paper that Professor Hazel-tine used the expression "mutual conductance," a term that has since become as much a part of radio language as have antennas and batteries. Professor Hazel-tine asserts that all of his subsequent radio work and whatever success

he has achieved may be traced to that paper.

Wireless was claiming more and more of Professor Hazel-tine's time. The following summer he devoted to experimental work in radio telegraphy and telephony in conjunction with Mr. Paul Ware. Later Mr. Ware joined the Signal Corps of the United States Army where he continued his research and produced a valuable portable set that has since been adopted as a standard equipment by the Signal Corps.

Meanwhile Professor Hazel-tine was also conducting a radio and buzzer class to train operators for the Signal Corps. And then when Professor Ganz died, Professor Hazel-tine was appointed in his place to serve as head of the Department of Electrical Engineering.

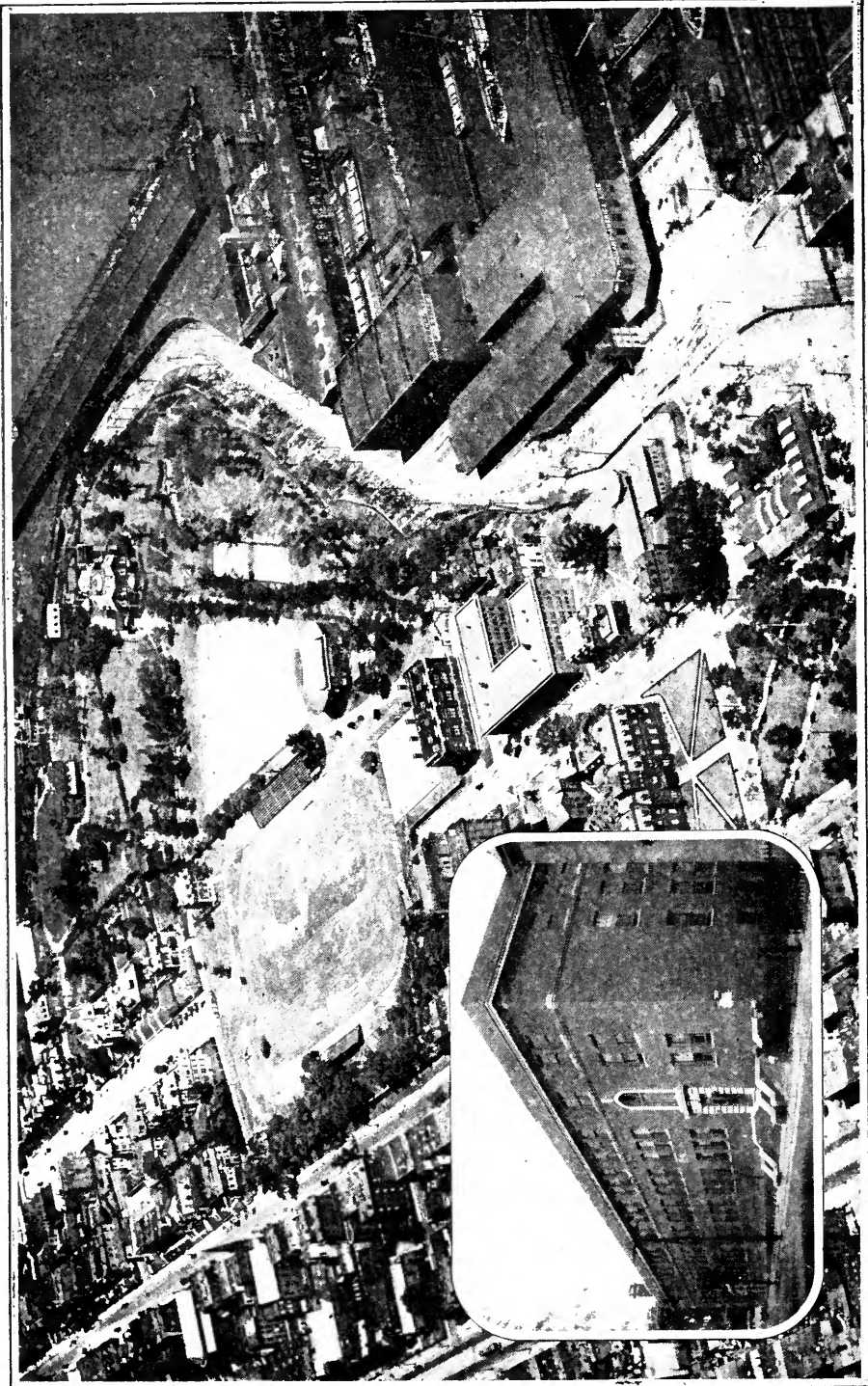

AN AIRPLANE VIEW OF STEVENS INSTITUTE Of Technology, in Hoboken, where Professor Hazeltime teaches. Hudson River piers can be seen to the right. The insert shows the Electrical Engineering building

THE SE 1420

DURING the following year I was asked to join the technical staff of the radio laboratory at the Navy Yard at Washington," he narrates. "I spent the summer in Washington doing miscellaneous development work and in the early fall I designed a radio receiver which was standardized by the Navy Department and has been in wide use ever since. To Naval operators it is known as SE 1420. This receiver contained several novel features, and its design was of particular interest to me because it was based on the theoretical formulæ which I myself had evolved and which were incorporated in my paper on 'Oscillating Audion Circuits.' These methods were borne out so well by experiment that only a single shop model was constructed on which a few minor adjustments had to be made before the final drawings and specifications were prepared for the submission of bids.

"In the midst of my work I was stricken with an attack of influenza which kept me away from the laboratory for a few weeks. On my return I found that another member of the technical staff had practically com-

pleted the development of a receiver similar to my own. The officer in charge of the work, Lieutenant W. A. Eaton, suggested that I abandon my development on the ground that time was pressing and that the other receiver was nearly ready. Had he given me definite instructions I would, of course, have obeyed him. But inasmuch as he merely expressed a wish that I do so and because I had great confidence in my own design, I felt justified in continuing with my work. The result was that when these receivers were tested mine was shown to be distinctly superior to the other and it was eventually adopted. Although it is strictly against the copy-book traditions I feel that a subordinate is justified in going against the wishes of his superior if he is confident that he is right and if he is not disobeying positive instructions.

ELIMINATING CAPACITY COUPLING

IN THE design of this Navy receiver I was particularly interested in trying to eliminate capacity coupling between the primary and the secondary circuits, for experience had shown me that this was a source of much interference in reception. By suitable shielding I was able to eliminate all capacity

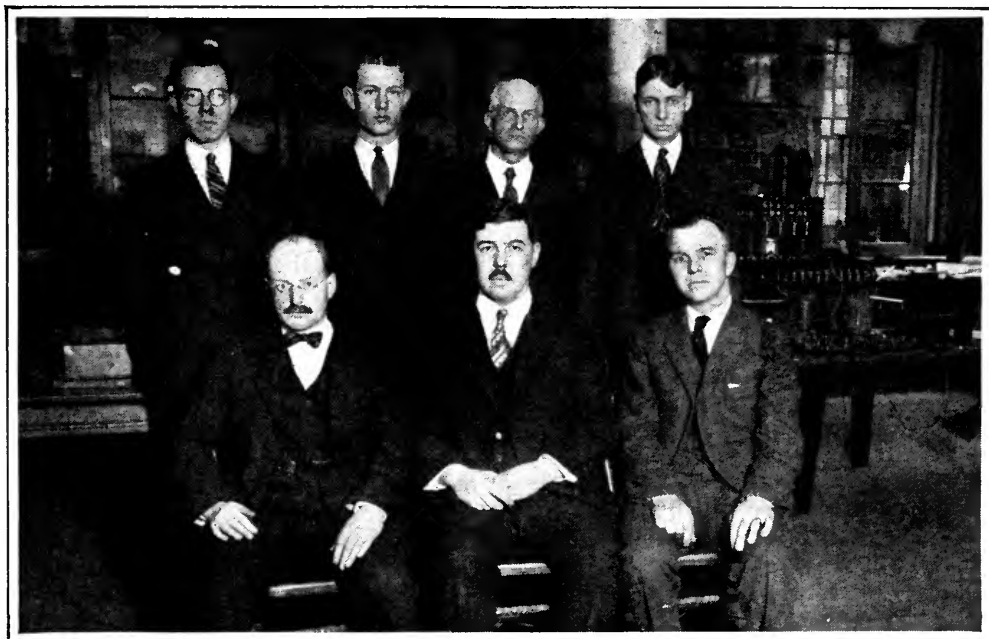

THE STAFF OF THE ELECTRICAL ENGINEERING DEPARTMENT

Of Stevens Institute of Technology. Professor Hazeltine, head of the Department, is seated in the first row, center. Front row, left to right, Professor F. C. Stockwell, Professor L. A. Hazeltine, W. P. Powers. Back row, H. L. Paulding, V. C. McNabb, Samuel Slingerland, and H. C. Roters

coupling in the primary and secondary circuits except between two coils, one of which was necessarily in the field of the other. Then it occurred to me that I could minimize this coupling by partially shielding one of these coils through an auxiliary coil wound over it. I realized that this coil would pick up some current, and I quickly saw that this current might be employed to neutralize whatever capacity coupling remained. This was the first thought of capacity neutralization that I had, and I did not realize at the time that it was destined to be what one might call the keystone of the neutrodyne. The neutralization was actually incorporated in the Navy receiver although it was of the nature of a refinement rather than of a necessity.

"Later I attempted the design of an audio-frequency amplifier which would give a particularly high amplification, but after a time I came to the conclusion that such an amplifier would oscillate persistently on account of the capacity coupling between the plate and the grid of the vacuum tube, in its circuit, for the plate and the grid circuits would be connected to similar transformers and would therefore be in resonance—a condition particularly conducive to oscillation. Almost at once I saw the solution—the deleterious capacity coupling. I suppose that my experience with the Navy receiver helped me to reason out the method which I thus evolved. My experience seems to me to be an illustration of the adage that the realization of a problem is frequently more important and more difficult than its solution. This neutralization of capacity coupling in vacuum tubes was the basis of the neutrodyne circuit, the practical development of which came several years later.

THE WAY TO SOLVE PROBLEMS—SOLVE THEM

IN 1919 I started to devote my time to a study of the application of three-electrode vacuum tubes to the various problems of power conversion, with efficiency the primary object. This work was to some extent a continuation of my earlier work on oscillating circuits, for the form of conversion which I first investigated was from direct current to high-frequency current as used for radio transmission. The work was carried on much further, however, in order that it might include conversion of alternating current power into direct current power, of one frequency into another frequency, of direct current into alternating current of controllable frequency, and so forth. This new subject

was a valuable background for my other work and made me realize that although two problems might not be closely related, they might, nevertheless, have a common ground in their respective solutions.

"In my college work I constantly see many boys who seem quicker than I in absorbing mathematical theories, but they have not the fondness for work that leads to original investigations. I have long believed that the prime requisite for success along mathematical lines—and this applies to all scientific progress—is not so much a natural ability, as it is a certain fondness for the subject. The only way to learn to solve problems is to solve them.

"I was engaged in the development of radio receivers during the fall of 1922 when my attention was directed to the immense possibilities of a receiver employing tuned radio frequency amplification. I knew that the great limitation of this type of receiver, which had thus far prevented its successful introduction, was in its strong tendency to oscillate because of the feed-back of the capacity coupling of the vacuum tube. This feed-back was accentuated by the tuned input and output circuits. I realized that my earlier work on the neutralization of this capacity coupling was directly applicable. A model receiver was constructed to incorporate these ideas and it was christened the neutrodyne.

"During this period, several manufacturers were eager to obtain a receiver of this sort, and Mr. I. P. Rodman, an officer of the present Garod Corporation who had become convinced of the great value of a tuned radio-frequency amplifier, had much to do with its development. The neutrodyne was first brought before the public at a meeting of the Radio Club of America in March, 1923.

HOW INVENTIONS ARE MADE.

THERE is much curiosity as to how inventions are made. In the earlier development of an art, most inventions are the results of experimental discoveries, and this is often the case even in their subsequent growth. For example, Armstrong's inventions of regeneration and super-regeneration come under this category. My inventions, on the other hand, have all been the result of theoretical studies, verified and modified by later experimental work. Again some inventions are the result of mathematical analysis as, for example, Pupin's and Campbell's loading coils on electrical filters in telephone lines. Although I have used mathematical analysis

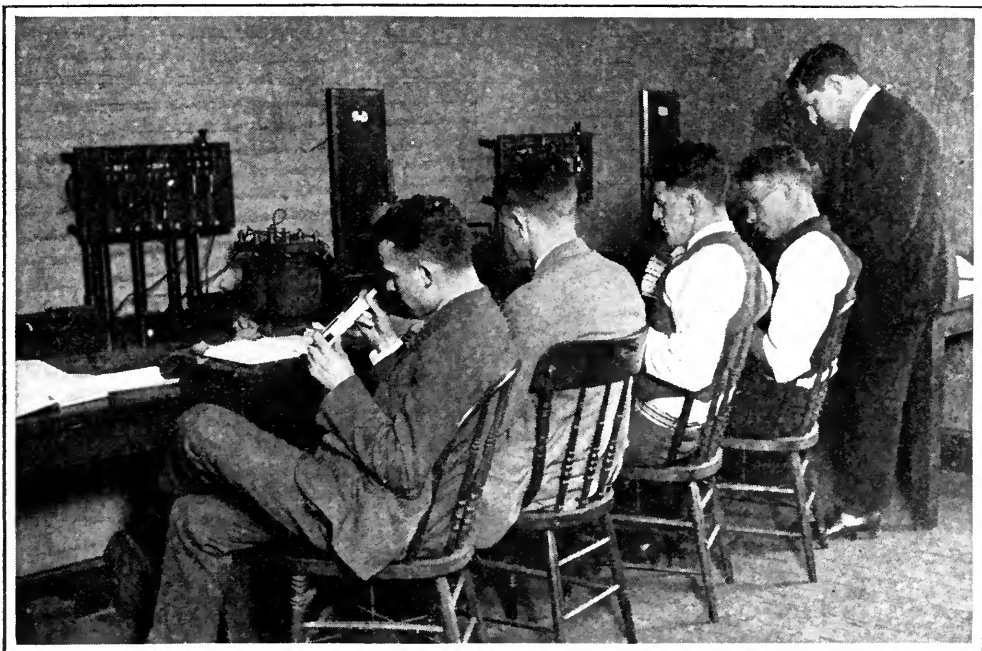

PROFESSOR HAZELTINE AND A CLASS

At work in a laboratory in the Department of Electrical Engineering at Stevens Institute at Hoboken, New Jersey

quite freely in my studies, it so happens that my inventions have been based on elementary technical considerations and can be fully described either with or without the most elementary sort of mathematics.

"Some inventions are made deliberately; that is, the inventor has a problem before him which he attacks in every way that he can think of until he solves it. It was in this manner that I made my invention of capacity coupling neutralization as applied to vacuum tubes and my high efficiency arrangements for power conversion with vacuum tubes.

"It is interesting to compare the problems which confronted the engineers of a few years ago with those which puzzle them to-day. In the days immediately following Armstrong's regenerative work, the great problem was to get vacuum tubes to oscillate, and I have spent many hours in trying to produce oscillations in circuits where the conditions were essentially unfavorable. In the Navy

receivers which preceded mine, the idea of obtaining oscillations under all conditions of coupling and wavelength had been definitely abandoned and it required all of the refinement of calculation of which I was capable to produce controllable oscillation in my own receiver.

"The problem of tuned radio frequency amplification, however, has been solved by the elimination of oscillations and I have spent as many hours getting rid of stray coupling and thereby stopping all tendency to oscillate as I have previously devoted to the encouragement of oscillation. So radio progresses."

It may be that Professor Hazeltine has used the same method of progress for himself. In any event, he has come up by almost pure mathematical processes to vindicate the student. He has made inventions that others have repeatedly failed to approximate, and he has placed himself in the foreground of important figures in the technical world to-day.

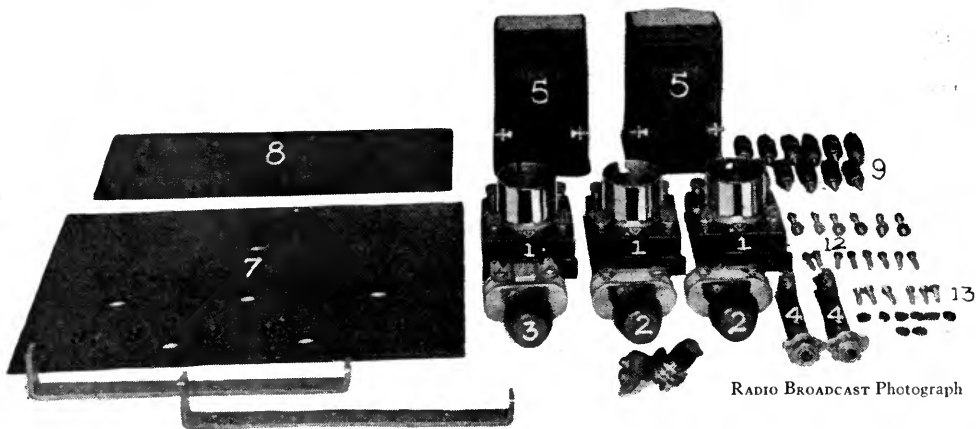

RADIO BROADCAST Photograph

FIG. 1

A parts picture. With the exception of the fixed condenser, all the parts entering in the construction of the detector amplifier are shown here. The numbers correspond with those of the parts list

How to Build a Two-Stage Detector-Amplifier Unit

BY JOHN B. BRENNAN

WE BELIEVE that radio constructors are becoming more and more interested in building receivers that will produce signals of excellent quality. As Mr. Brennan, technical editor of this magazine, brings out in this article, it is not now so important just how much noise a receiver will deliver, or how far it can be heard, but the quality of the program it produces. This unit, which is designed to fit with the two-stage radio-frequency amplifier unit described by the same author in this magazine for May, 1925, has been especially designed to give the best possible quality. The cost of parts is not high, and the constructor will find that assembly and wiring is quite easy.—THE EDITOR

SLOWLY but surely the trend in radio is swinging toward quality. We are learning that it is not how much, but how good that counts in radio.

There was a time when the radio store which had the largest horn sticking out its front window with a power amplifier behind it, assumed a kind of local radio supremacy due entirely to the pure force of the racket. Times have fortunately changed, and to-day we see many dignified if modest radio establishments equipped with individual listening-in booths where receivers are on display and demonstration.

So, too, the change has been felt in the design of radio apparatus. Parts and complete sets have been materially improved. Good voice and music quality and perfectness of

loud speaker reproduction have assumed their rightful importance in design and construction. That old term "tremendous loud speaker volume" is slowly slipping into the discard. It is being helped along by an occasional shove in the form of an amplifier which produces loud speaker signals with clarity and fidelity.

This paper describes such an amplifier.

WHAT DO WE WANT IN AN AMPLIFIER?

TO BE efficient, a detector and amplifier must have the qualifications of sensitivity, honesty of reproduction, ease of control, and must produce loud speaker volume sufficient for dancing. Its construction must be simple.

The sensitivity largely depends upon the type of tuner employed to tune the incoming

signal before it reaches the detector tube. However, the detector tube must also be possessed of qualities which will make of it a sensitive rectifier of these signals.

Honesty of reproduction, or in other words, the property of the amplifier to repeat faithfully the sounds as transmitted, is a function governed by the selection of a suitable audio-frequency transformer, plus the intelligent use of A, B, and C batteries.

All detector-amplifier circuits are pretty much alike. Their differences are mainly in the design which affects the control of the various parts entering into the construction of a completed unit. Undoubtedly a unit may be produced in which everything possible is variable: C battery adjustment to the amplifiers, grid leak, grid condenser, tapped transformer primaries and secondaries, and B battery voltages. It is hardly necessary to state that the tubes would be individually controlled by separate rheostats. However, a unit such as this would soon lose its value if it were to be used in a permanent installation where there would be no need for all these controls once a satisfactory adjustment has been obtained. Such a completely variable unit would rather be suitable for the laboratory.

The volume produced by an audio amplifier

depends upon the number of stages of amplification which may safely be used without overloading the amplifier tubes. Volume also depends upon the sensitivity of the detector and the ability of the amplifier to take whatever is produced in the detector and amplify it without altering the signal characteristics. Briefly explained, this means that some amplifying transformers have the tendency to favor some voice and music notes over others, depending upon the electrical and mechanical makeup of the transformer. The distributed capacity in transformer windings causes a favoring of the lower frequencies over the higher frequencies. Also, when little iron is used in the core construction, it becomes over-saturated by the forceful variations of electromagnetic flux and prevents the transformer from functioning successfully.

GOOD QUALITY AND SUFFICIENT VOLUME

THE detector and two-stage audio-frequency amplifier described here is the result of experimentation along the lines as explained above. It has been reduced to a practicable working unit producing a very high quality of signal with plenty of volume.

This detector-amplifier may be used with any tuner now available, but has been especi-

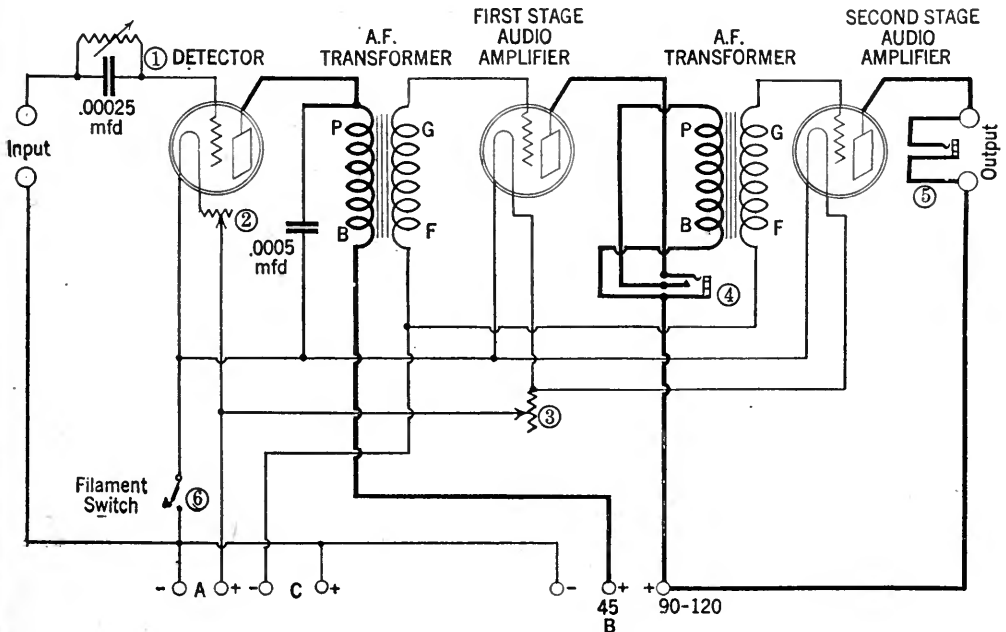
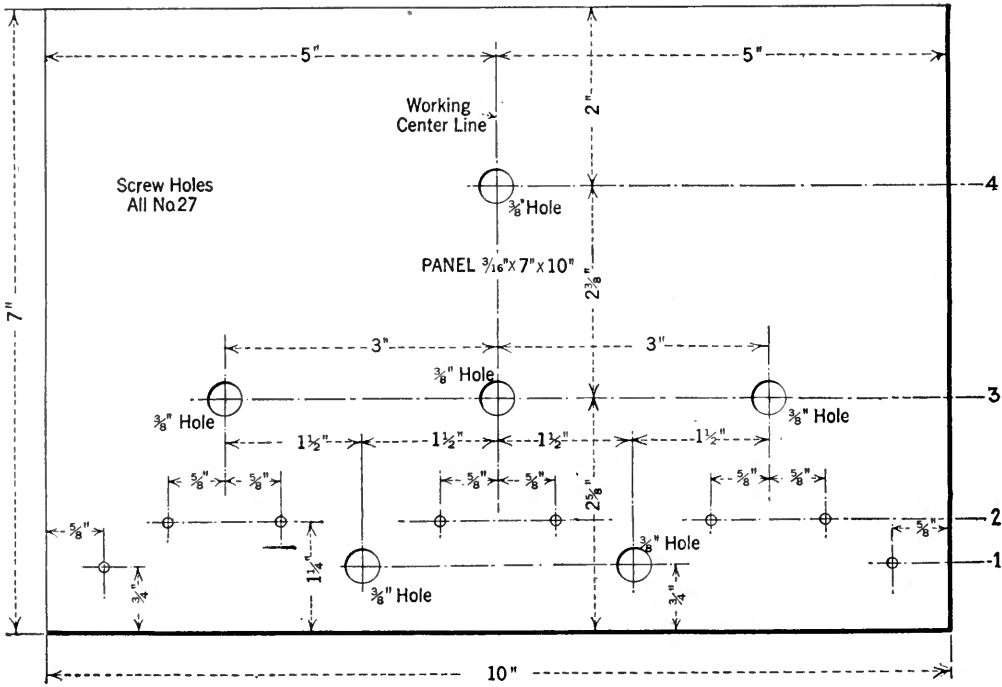

FIG. 2

The circuit of the detector-amplifier. The numbered units refer to those panel controls as marked on the panel illustration Fig. 3. In wiring it is well to make frequent use of this circuit and the schematic wiring diagram, Fig. 7



FIGS. 3 AND 4

This front view of the panel indicates the symmetrical layout which has not caused any sacrificing in efficiency for the sake of appearance. Ample room on the upper side allows for the mounting of a filament voltmeter and plate milliammeter or plate voltmeter. The working drawing above shows the panel layout



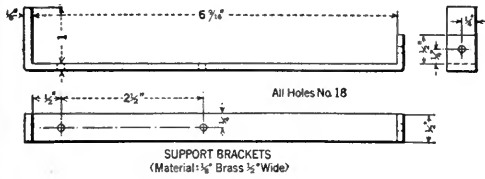

FIG. 6

The angle bracket details. Two are required

ally designed as the audio unit for the two stage radio-frequency amplifier described in the May, 1925, RADIO BROADCAST.

The circuit comprises a vacuum tube detector with variable grid leak and independent filament rheostat and a two-stage audio amplifier with filament controlled by one rheostat. Large core audio-frequency transformers of a ratio of approximately 3 to 1, and a C battery bias upon the grids of the amplifying tubes are important items entering into the construction. None of the adjustments is exceedingly critical but are found to be of actual necessity when maximum service is desired.

All the binding posts for the connection of the tuner, batteries and loud speaker are mounted upon the rear of a bakelite shelf which also supports the audio transformers.

A filament switch, the grid leak and condenser, rheostats, sockets and jacks are mounted upon the panel. The bakelite sub-base is mounted upon the brass angle brackets which are fastened to the back of the panel.

WHAT PARTS TO USE IN THIS UNIT

SATISFACTORY results with this design depend entirely upon the selection of many of the same parts as employed in our construction. This is quite logical. It is probable that another type of amplifier can be designed using other parts—but that's another story.

The parts employed in the construction of this unit are listed as follows:

1. 3 Federal sockets—panel mounting
2. 2 Bradleystats
3. 1 Bradleyleak, with .00025 mfd. condenser
4. 2 Carter Jacks, 1 open single-circuit, 1 closed single-circuit
5. 2 Rauland Lyric audio-frequency transformers ratio 3.95 to 1
6. 1 Carter filament switch
7. 1 Panel 7 x 10 x 1/8 inches
8. 1 Panel 3 1/2 x 9 1/8 x 1/16 inches
9. 10 Eby binding posts
10. Brass strip 20 x 1/2 x 1/8 inches
11. Bus wire—lugs
12. 14 1/2 inch x 3/32 Round head machine screws with hex nuts.
13. 6 1/2 inch x 3/32 Flat head machine screws with hex nuts
14. 1 —.0005 mfd. fixed condenser

The reader will probably ask, "can other transformers be used instead of those shown?" Of course, yes, but so can other parts be used throughout the construction. If this variation is allowed in parts selected, the individual constructor would have to lay out his own job. He would, of necessity, have to rearrange the

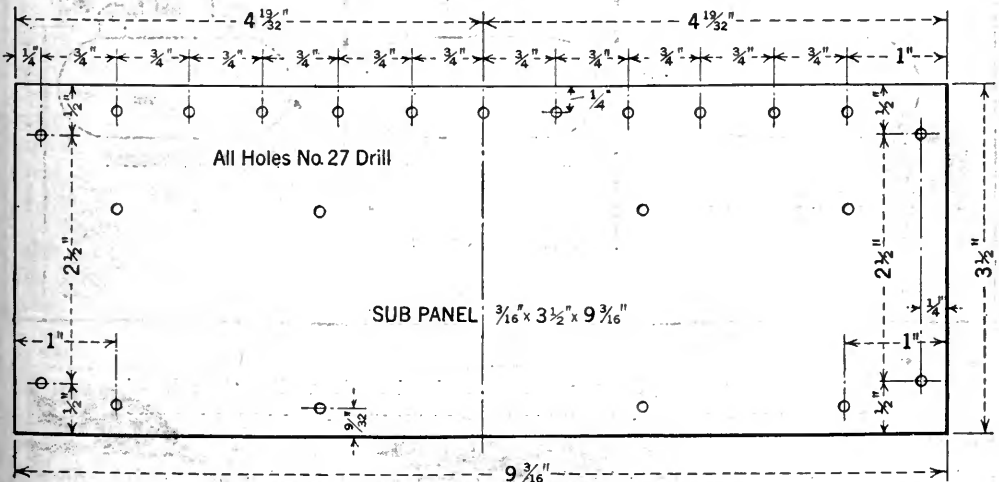

FIG. 5

In the layout of the sub-base, the dimensions are marked starting from the center line. By actually placing the audio transformers in place, their mounting holes may be scribed

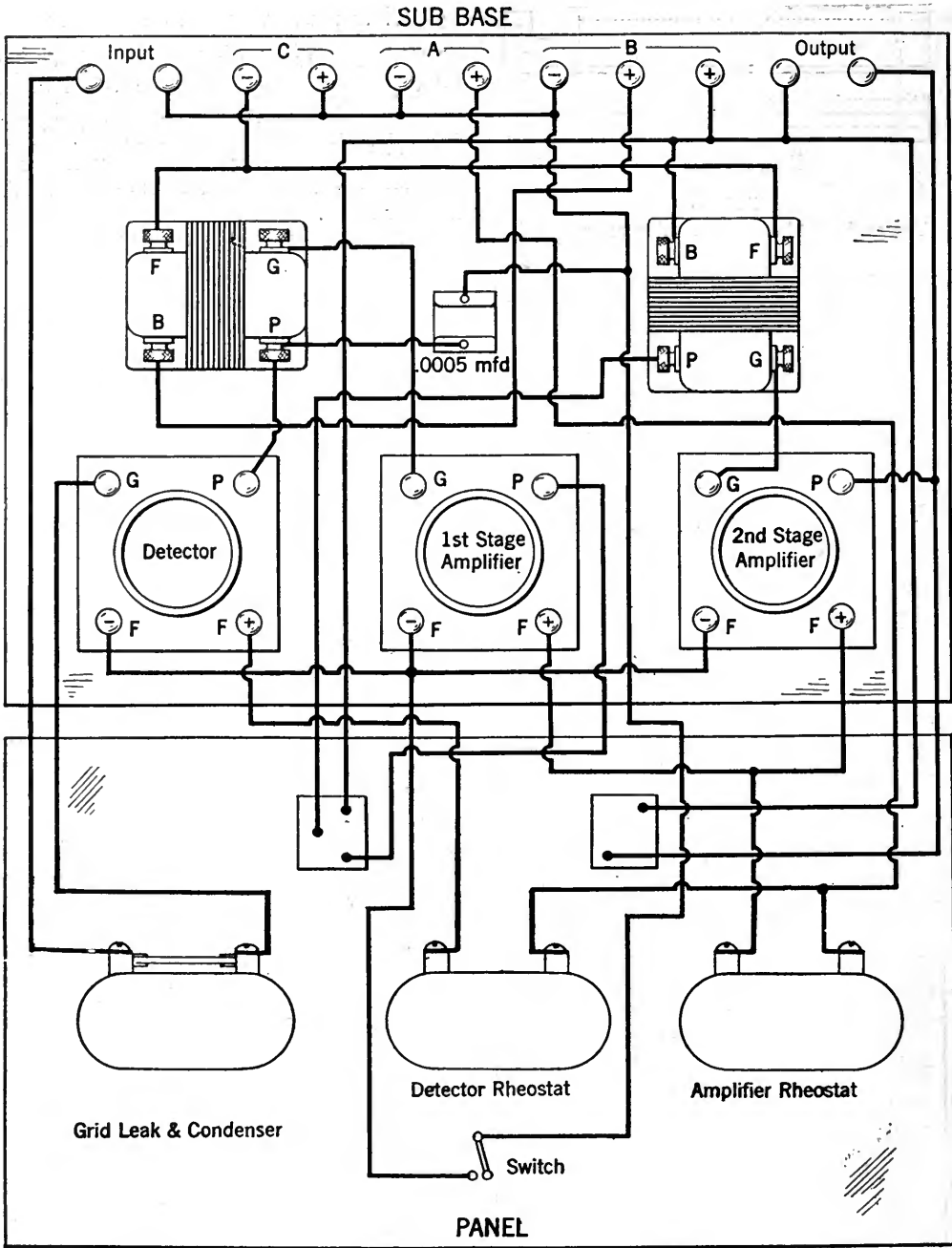

FIG. 7

Is a schematic wiring diagram of the completed receiver. For the sake of clearness, the panel is represented as being on the same plane as the sub-base

various mounting holes on the panel and also the sub-panel holes would be changed.

If the parts were not thoughtfully selected there would be nothing left but the idea and

scheme of construction and that is hardly new. Therefore for those who wish to benefit by the experience gained in the test of several types of apparatus, it is suggested that they con-



RADIO BROADCAST Photograph

form to the selection of parts as closely as possible to the list as shown.

The heart of the unit is the two audio-frequency transformers. They have been selected because of the large cores upon which are wound plenty of wire. These two features

In laying out the panel, place it face down on a table with its length running right and left. Now divide the length into two sections evenly, both of five inches each. The dividing line is the working center line. Working up, three quarters of an inch from the bottom

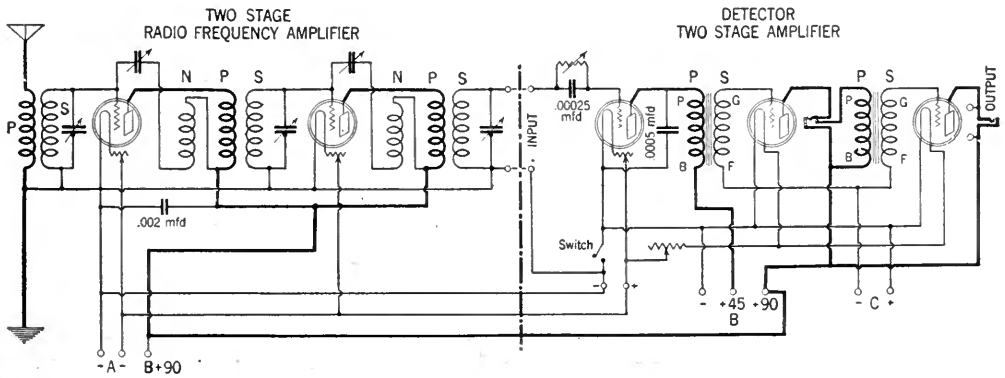

FIG. 8

How the detector two-stage amplifier would be connected to the two-stage radio-frequency amplifier described in the May, 1925, RADIO BROADCAST. The cut above shows the two units connected

alone prevent over-saturation and insure against overloading.

Those used in this amplifier are of a low ratio and are capable of taking a very strong signal and amplifying it without changing its characteristics. The circuit employed is that of Fig. 2.

The numbered symbols in Fig. 2 are those with variable controls that are mounted on the panel. They may be identified in the panel illustration Fig. 3.

ASSEMBLY IS EASY USING THE NUMBERS

THE construction of the detector-amplifier is almost entirely a matter of assembly, and wiring. We suggest proceeding as follows:—After the parts have been obtained, the panels are prepared by drilling all the holes and graining the surface by rubbing with fine emery paper.

scribe a line (1) across the length of the panel. On it will be located the two jacks. Then one half inch above it scribe another line (2) all the way across. This is for the socket mounting holes. Another line (3) is scribed

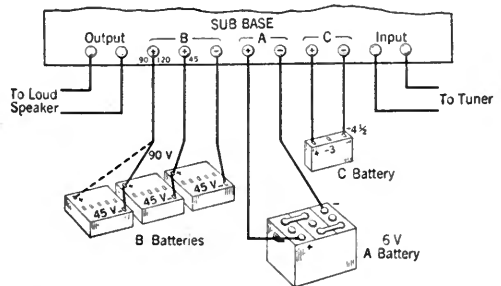

FIG. 9

Here is how the batteries, A, B, and C are connected to the binding posts on the sub-base

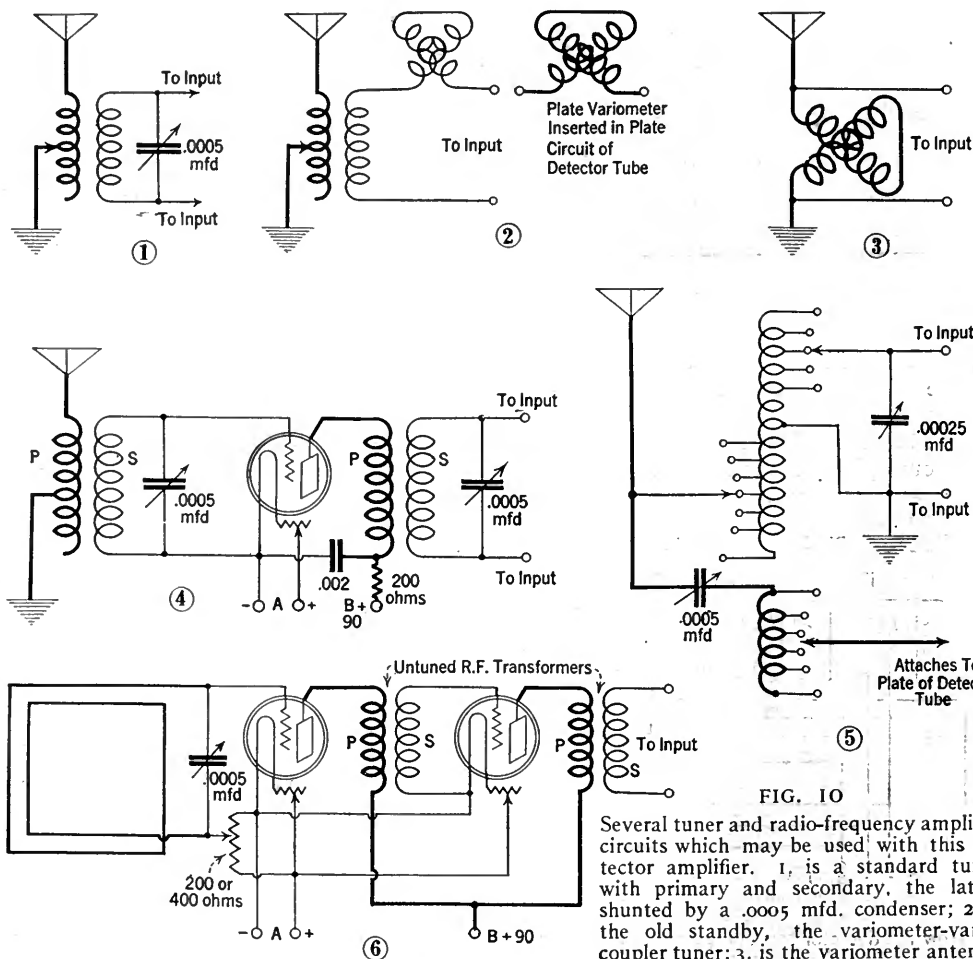

FIG. 10

Several tuner and radio-frequency amplifier circuits which may be used with this detector amplifier. 1, is a standard tuner with primary and secondary, the latter shunted by a .0005 mfd. condenser; 2, is the old standby, the variometer-variocoupler tuner; 3, is the variometer antenna tuner; 4, a non-radiating radio-frequency amplifier and tuner; 5, the Reinartz tuner; and 6, a loop and r. f. circuit. In the detector circuit, the return of the grid circuit is made to the negative side of the A battery line. If results are not satisfactory, try making this connection on the positive side of the A supply

$1\frac{3}{8}$ inches above the last one for the grid leak and two rheostats. The filament switch hole intersection line (4) is marked directly on the center line $2\frac{3}{8}$ inches above the line No. 3.

Working out from the center line on line No. 1, the two jack holes are located $1\frac{1}{2}$ inches away. The mounting holes for the brass brackets are located on this line $\frac{5}{8}$ of an inch from the sides of the panel.

Now jump up to line No. 3 for the rheostats and grid leak, etc. One is centrally located on the center line and the other is 3 inches to the side as is the grid leak hole. After locating these three points, continue the scribe lines down so as to intersect line No. 2. Then coming back to line No. 2 the socket mounting holes are located $\frac{5}{8}$ of an inch either side of the point of intersection of the rheostat hole lines. The complete layout is shown in Fig. 4.

This completes the panel. The sub-base dimensions may be laid off in a similar manner and are shown in Fig. 5.

The binding posts are situated three quarters of an inch from each other beginning at the center line. The holes for screws holding the sub-base to the brass brackets are located on each end $\frac{1}{4}$ of an inch in from the edge. The transformer holes are given but are not accurate for all transformers of the same manufacture. Therefore, in laying out these holes it is well to place the transformers on the base so that the holes on one side are $\frac{3}{8}$ of an inch from the front edge. Then holding

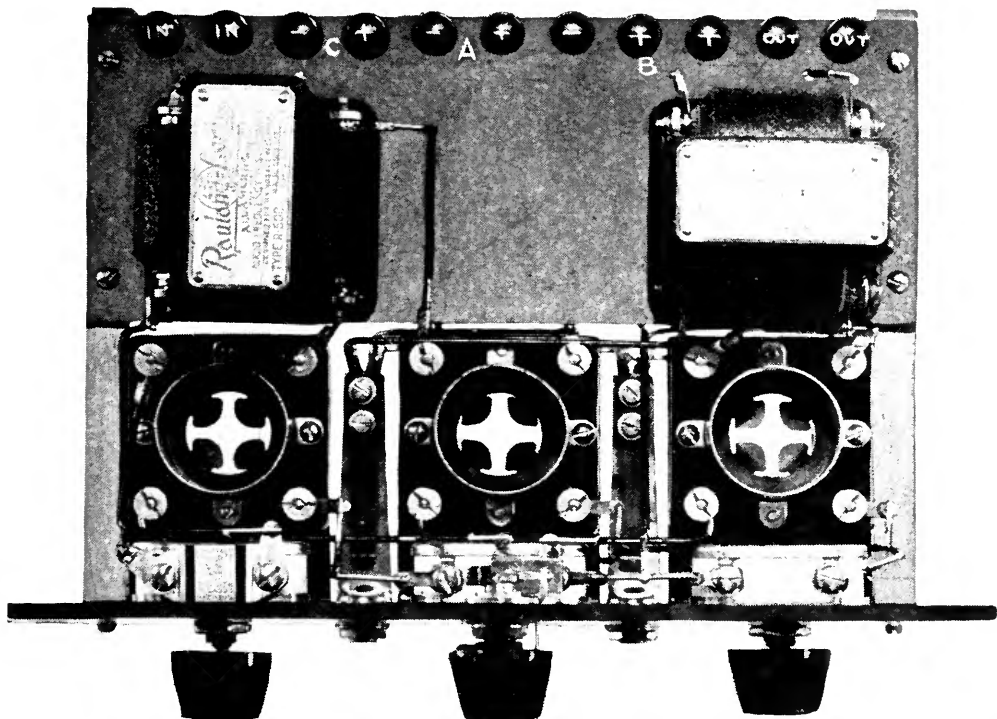

RADIO BROADCAST Photographs

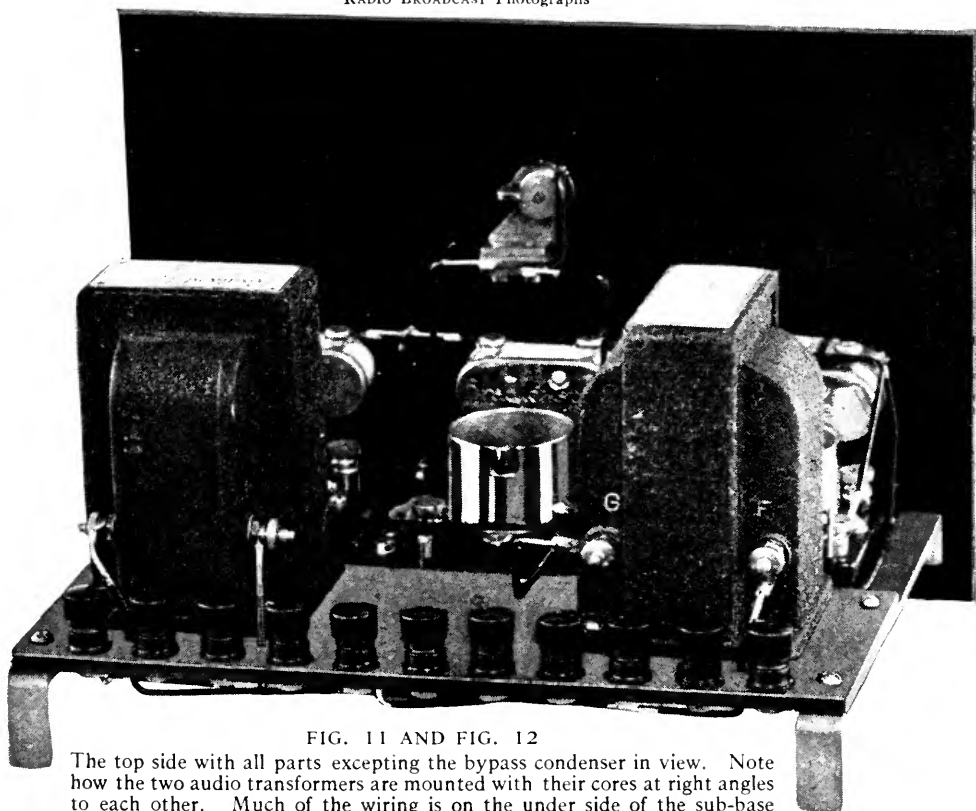

FIG. 11 AND FIG. 12

The top side with all parts excepting the bypass condenser in view. Note how the two audio transformers are mounted with their cores at right angles to each other. Much of the wiring is on the under side of the sub-base

the transformer in place, mark the holes with a scriber.

The brass brackets are bent and drilled in accordance with the layout shown in Fig. 6.

With this preliminary preparation accounted for, the work of assembly is next in line. The several parts are mounted in order named, from the top of the panel down; first filament switch, then rheostats, and grid leak, next sockets and finally jacks.

For the sub-base, first mount all the binding posts having the lugs on the under side of the panel and pointing in toward its middle. Next mount the panel upon the brackets and after this is done, secure the two transformers firmly with $\frac{1}{2}$ -inch x $\frac{5}{8}$ round head machine screws. The cores are placed at right angles to each other as may be seen from the schematic wiring diagram Fig. 7 and the illustrations.

The completed sub-base unit is fastened to the panel by two round head brass or nickel plated machine screws $\frac{1}{2}$ inch long.

THE UNIT

IN AN assembly job as compact as this, it is absolutely essential that insulated wire be used, at least where there is danger of short circuits. In the unit described, insulated wire has been used throughout. Contrary to what one might think, the wiring job is simplicity itself. It is only to be remembered that the wires should run direct from one part to the other without unduly twisting or bending them. The schematic wiring diagram in Fig. 7 will be of aid here.

Wherever possible, lugs have been clamped down under terminal nuts to provide an easily accessible point of soldering.

As a standard detector-two-stage audio amplifier, this unit is admirable for use around the laboratory where the experimenter is frequently trying new tuner circuits and requires a means for detecting and amplifying his received signal. Its primary purpose is for use with the two-stage radio-frequency amplifier described in the May, 1925, RADIO BROADCAST.

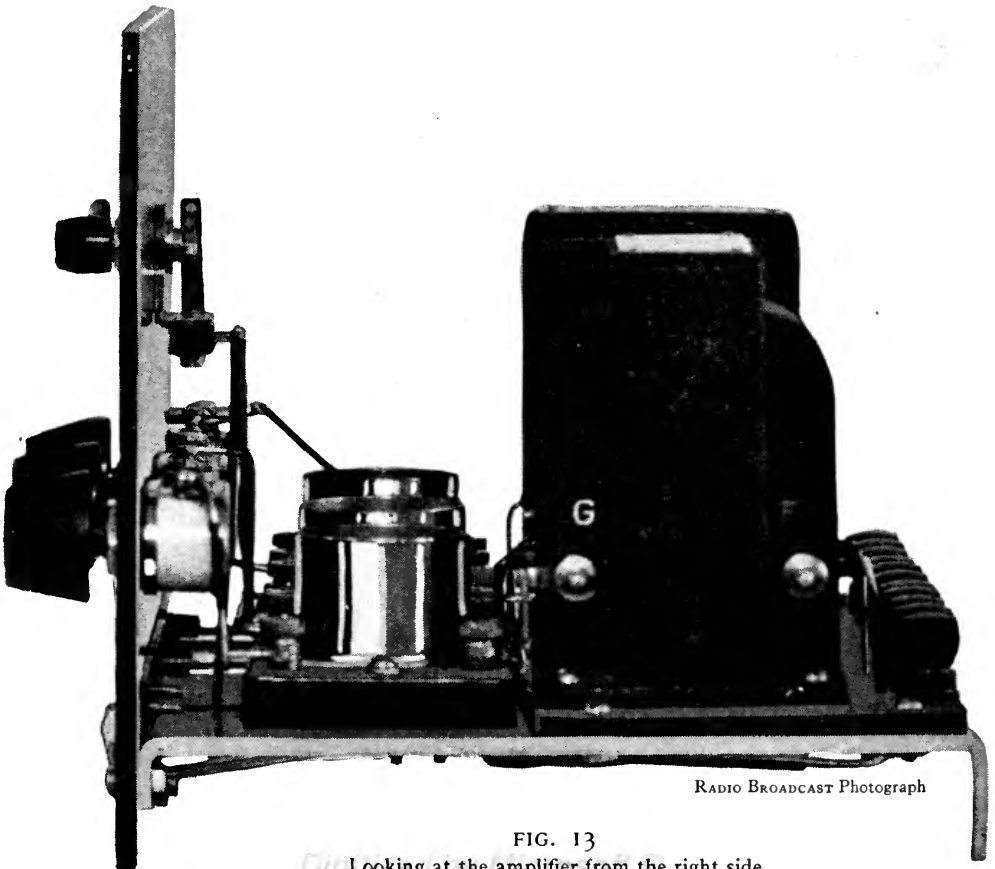

RADIO BROADCAST Photograph

FIG. 13

Looking at the amplifier from the right side

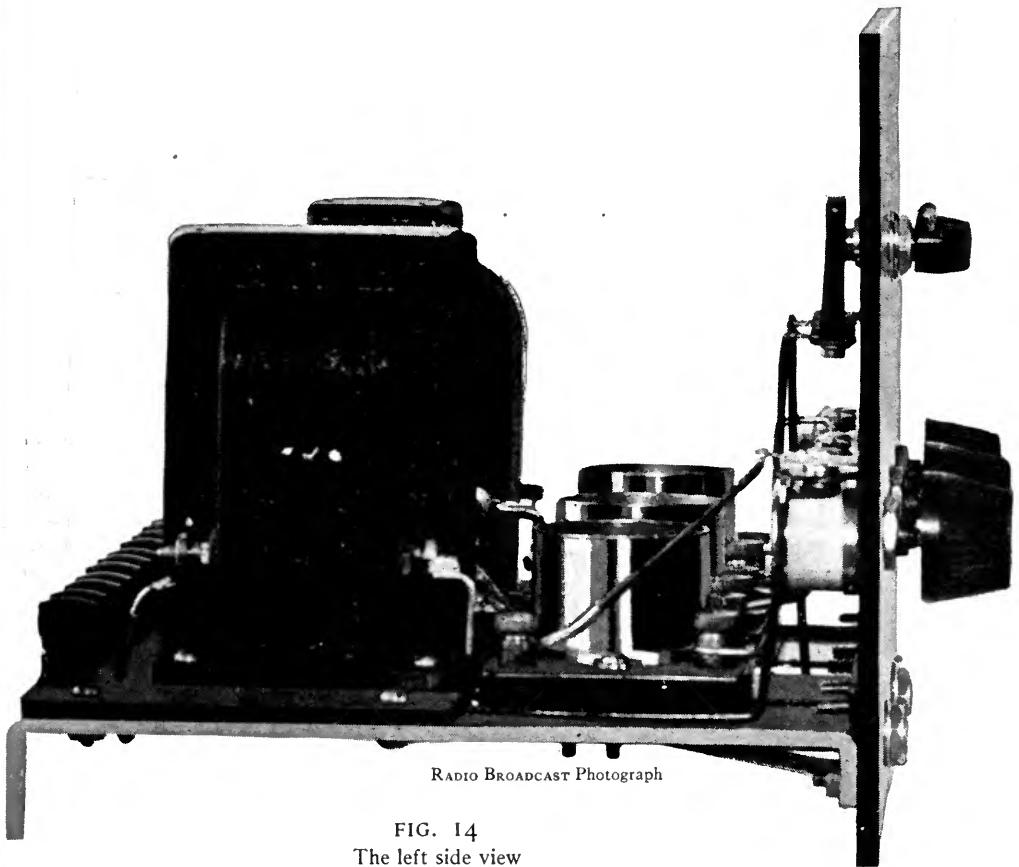

RADIO BROADCAST Photograph

FIG. 14
The left side view

The circuit diagram, Fig. 8, shows how these two units may be connected together.

Plate voltages of from 90 to 120 may be used on the two audio stages while for the detector 45 to 90 volts will be suitable. No definite voltage requirements are specified as this depends entirely upon the tubes and transformers used. Six-volt tubes will probably give greater satisfaction in this unit, although it is of course entirely possible to use one and one half and three-volt tubes.

The loud speaker may either be plugged into the last jack or the cord tips fastened in the output binding posts. The jack for the first stage is not of the conventional double-circuit type but is a single closed-circuit jack which includes the phones or loud speaker in series with the primary of the first transformer when the plug is inserted.

OPERATION OF THE AMPLIFIER

ONCE the unit has been adjusted for one particular time, for instance, an evening enjoyment of a radio program, there

is nothing that need be touched with the possible exception of the grid leak. Tubes should be burned only as brightly as is consistent with clear and sufficient volume. To go beyond this point usually results in decidedly decreasing the life of the tube.

The batteries are connected to the binding posts of the amplifier as shown in Fig. 9. The C battery voltage will vary conversely with the B battery voltage applied and may conform with this table:

<i>B Volts</i>	<i>C Volts</i>
80	3.0 to 4.5
100	4.5 to 6.0
120	6.0 to 9.0
150	9.0 to 12.0

The tuner unit output is connected to the detector-amplifier input at its input binding posts. Amplifier output posts are provided which allows the use of a loud speaker without plugging into the jack. Several tuner and radio frequency circuits with which this unit might be used are shown in Fig. 10.

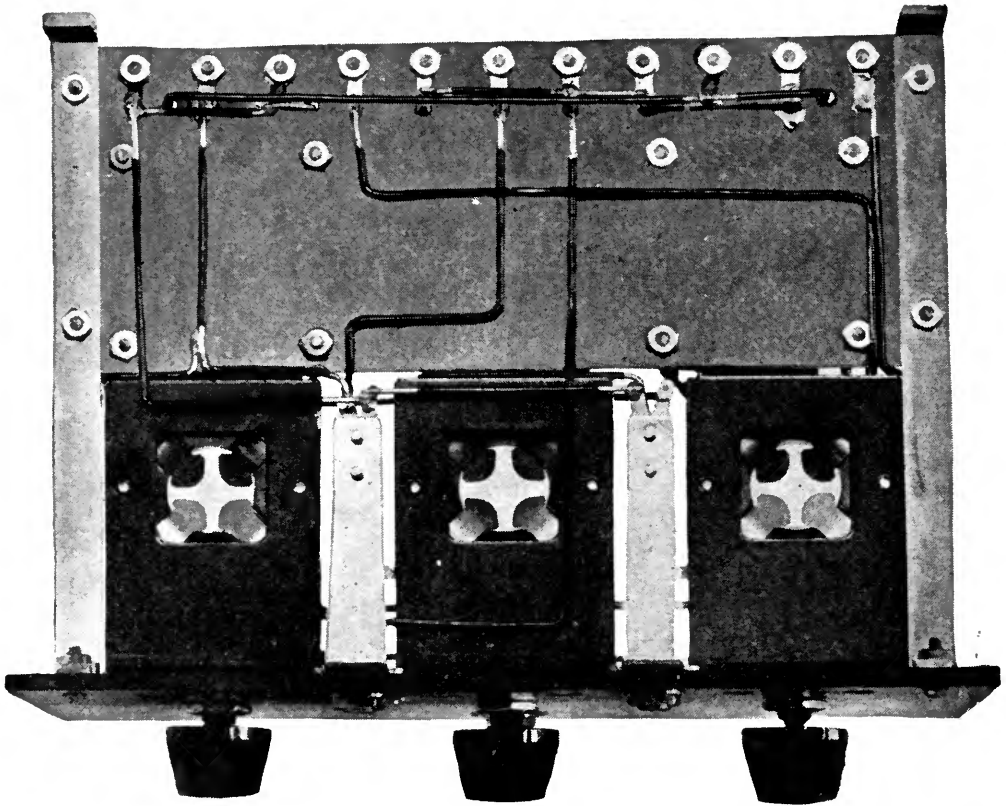

RADIO BROADCAST Photograph

FIG. 15

Simplicity in wiring is clearly indicated in this bottom view. It also shows the need for accuracy in layout, as there is not much room to spare for the sockets between the two brass brackets

If there is the slightest trace of a high-pitched singing noise, it is well to ground the negative side of the A battery and the cores of both audio-frequency transformers.

Where trouble is apt to be encountered, it is suggested that the constructor proceed first by re-checking the entire circuit diagram with the wired circuit of the unit. Sometimes it is possible that transformer windings are open-circuited or bypass condensers short-circuited. Be sure also that positive contact is made between the several blades of the jacks and that the filament switch is working correctly. Tube prongs may also be bent down too far,

preventing the tube from making contact with the socket blades.

From the several assembly and wiring photographs it will be seen that some leads have been passed through holes drilled for the purpose in the sub-base. Many of the leads running from the sub-base assembly to the panel pass through the narrow space between the sub-base and the rear of the sockets.

When enclosed in a suitable cabinet, this detector-amplifier in appearance will grace any installation and is admirably adapted for the special requirements of the experimenter.

|| The material appearing in this magazine is fully protected by copyright, and editors of periodicals are advised that unauthorized publication of circuit diagrams, technical descriptions, and parts or the whole of articles, without due permission and credit, is an infraction of the law. Those who wish to reprint material appearing in these pages are asked to communicate with the editor.

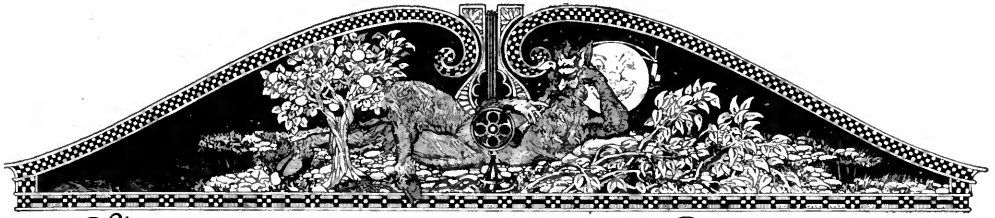

The Listeners' Point of View Conducted by Kingsley Welles

Summer Radio Programs Are Attractive

WE IMAGINE that the broadcast program directors, harassed fellows that they are, breathe a sigh of relief when the summer season comes around. A glance at the daily radio programs in the newspapers, bought these steamy summer days, shows that there is plenty of interesting entertainment which can be led into the willing maw of the domestic loud speaker. At the risk of incurring the wrath of those who make what is flip-pantly called a livelihood from the business of transportation, we should like to suggest that the faithful radio set can provide entertainment and amusement in the coolness of one's home which make a trip to the scene of the festivities entirely unnecessary.

Although the concert season has closed, and the members of orchestras which have been heard from many stations during the winter and spring with so much

pleasure have scattered, there are still many excellent bands which will be on the air from various stations during the summer. The United States Marine Band is probably the best known of musical organizations of this sort that can be heard during warm weather. Every Wednesday evening from five to six thirty, Eastern Standard Time, this band can be heard through stations wrc of Washington and wjz of New York.

These late afternoon concerts will supplement the regular weekly concerts played in the Sylvan Theatre at Washington which are broadcast every Thursday night from seven thirty to nine, Eastern standard time. WJAZ and eight others are broadcasting several concerts weekly of the Goldman band from the bandstand on the campus of New York University, beginning at 8:30 and concluding at 10:15 Eastern daylight saving time on the evenings concerned.

WJZ, WGY, and WRC will broad-



FRITZ REINER

The famous conductor of the Cincinnati Symphony Orchestra which has been heard over station WLW, of Cincinnati. Mr. Reiner, who is quoted elsewhere in this department, thinks that radio can do much to elevate American musical taste. His own activities through WLW have done a great deal toward giving broadcast listeners music of unequalled quality

cast three times weekly concerts of the New York Philharmonic Society. The orchestra plays in the Lewisohn Stadium, New York.

Listeners to wjz, of Detroit, remember with much pleasure the concerts of Scherman's Band which have been broadcast from Belle Isle park in that city. Alert program managers in many other cities promise bands of high grade.

And sporting events seem to get on the air more regularly during the warmer months, which is probably most simply explained by the fact that there is more activity of this sort at this time of year. The famous Indianapolis automobile races were broadcast from wgn at Chicago on Memorial Day with great success. College baseball games were on the air in many sections of the country in the weeks before academic doors closed for the summer holiday. wjz handled particularly well the job of reporting a recent game between Yale

and Princeton to say nothing of the Yale Commencement exercises in June.

Station wjz, of Chicago, is making plans to broadcast the classic Lake Michigan sailing yacht races between Chicago and Mackinac Island. A small short wave transmitter will be set up on a power boat which will follow the yachts as they speed up the lake.

It is unfortunate that one or more of the enterprising Eastern broadcasters do not arrange to broadcast more of the college crew races. wjz made a brave stab at it not long ago when they put a short wave transmitter aboard the yacht *Elco* in the Harlem with the capable Major J. Andrew White at the microphone and broadcast the Childs' Cup race between the eights of Columbia, Pennsylvania, and Syracuse. The Poughkeepsie races in June afforded a tremendously exciting event to listeners interested in sports. Major White at the traveling wjz microphone

brought his listeners along with him by the color and imagination of his picturesque descriptions.

In the main, out-of-door broadcasting is more successful than might be thought. Reverberations present in a large hall make the problem of properly broadcasting an orchestra or band most difficult. As Mr. Carl Dreher suggests this month in "As the Broadcaster Sees It" open air broadcasting is usually quiet and free from the unpleasant effects of sound, bouncing about where it should not go. And, barring the barking of disturbed and inquisitive dogs, and the squalling of tired children, the broadcaster who sets up microphone and speech amplifier in the open air is usually quite successful.

However, a few weeks ago, wjz was broadcasting the ceremonies incident to the unveil-



GOVERNOR NELLIE TAYLOE ROSS

Of Wyoming and Governor Clarence J. Morley of Colorado, before the microphone of KOA, at Denver. Governor Ross shares national honors with Governor "Ma" Ferguson, of Texas as the first members of their sex to guide the political destinies of an American state



MARION DAVIES

Who was heard at a "Motion Picture and Vaudeville Star's Radio Party" from station WIP, in Philadelphia

ing of a tablet to Thomas A. Edison, from Menlo Park, New Jersey. The speeches were in the open air and came through in excellent fashion. But the scene of the affair was close to the main line of a railroad, and at times during the broadcasting, the hasty puff of the engines came through the microphone with such force as to interrupt the words of the speakers. Governor Silzer, of New Jersey, who made one of the principal addresses,

remarked that the occasion was probably the first time that the State of New Jersey was in direct competition with the railroads.

Many of us have felt, during the broadcasting of a prize fight, to choose a happy example, that the miscellaneous noises—the cheering of the crowd, the gongs and bellow of the announcer in the ring—are a decidedly necessary and desirable part of the affair. The commercial noises of a railroad, however,



THE SANDMAN OF STATION KHJ

At Los Angeles. Those who have that unusual ability to talk to children instead of *down* to them are heard from many broadcasting stations, and the "Sandman" of KHJ is one of the most able and most popular of the broadcasters of this sort

are not much of an addition to most outdoor pick-ups.

A Statement of Policy

IT IS no easy task to take up "The Listener's Point of View" where Miss Mix left it. In the fourteen months that she wrote this department, she succeeded in building up a following of readers in all parts of the country which any writer might envy. This was natural indeed, for her comments and criticism combined in delightful fashion, great breadth of knowledge of matters musical and a charming style of presentation.

The present writer, readers willing, will attempt to carry on. His design involves news and comment of broadcasting stations, artists, and broadcast programs, and all else which is of the ether ethereal.

It was in February, 1924, that the editors of RADIO BROADCAST planned this department, and in the April, 1924, magazine that Miss Mix's first department appeared. A few days before the April number appeared on the news stands, the New York *Herald Tribune* began their daily broadcasting critique "Last Night on the Radio" written by the caustic Mr. Raymond Francis Yates, who used the name "Pioneer."

After that, it seemed as if newspaper and magazine radio critics increased even as the beasts of the field.

There are now probably anywhere from three to five million radio receivers in this country, if one accept the most credible estimates of those arithmetical persons who interminably compile statistics on the number of radio listeners. That chip falling where it may, however, it is our hope that some of the owners of the five million receivers may find something interesting in these pages each month. That object being attained, as J. Caesar would say, we hope to read your letters of opinion and comment on broadcasting—our mutual concern.

What Makes a Broadcasting Station Popular

IN THE first exciting days of broadcasting, the very act of receiving the sounds of

tinny phonograph records and the noisome regularities of a mechanical piano was regarded by the wondering public as a stunt, a kind of theatrical laboratory experiment. And many of our broadcast directors have never allowed that feeling to weaken in the minds of what they are pleased to call their clientele. While listeners are able to depend on this station and that for regular features of one sort or another, they look to others to supply them with something new, curious, *outré*.

Witness the Philadelphia broadcaster who sent a studio favorite in a diving suit to the bottom of the ocean near Atlantic City, where for some fifteen minutes he regaled his listeners with sub-aqueous, non-scientific platitudes. A year ago, much journalistic to-do was excited over the broadcasting of the sounds of the circus. And so we have had various attempts at broadcasting from an airplane, none of them especially successful.

The learned Secretary Wilbur arranged with his Naval radio and publicity experts to install a low powered broadcasting set on the *Los Angeles* when she made a recent all-day voyage over Philadelphia, laden with a cargo of merchants. Gar Wood's "race" between one of his speed boats and the Twentieth

Century Limited was reported by radio from an airplane flying over the racers on their two hour trip down the Hudson from Albany to New York. One hesitates to conjecture what the next stunt will be. In some respects our English friends are not far behind; was not the song of the nightingale broadcast from 210 to the tune of newspaper space, measurable only in feet?

The directors of broadcasting stations will admit, almost to a man, that they are, after four years, still experimenting. They are not yet really certain what the public wants. But we are certain that the public is primarily interested in the best. If a broadcasting station has gained a reputation for excellent classical music or for jazz music of good quality, or for good lectures and speeches, or whatnot, that station can be best kept in the

favor of the public by a continuance of the policy. We doubt very much that temporary bursts of publicity, gained from the studio presence of movie stars who tell radio listeners of their innermost thoughts, or by the broadcasting of a jazz melange from a steamship at dock can do much permanently to gain public favor. The station which daily meets the real wishes of its listeners is the one whose popularity will last.

An Orchestra Conductor Speaks About Radio

THE greatest hope for radio is that it may bring good music to all parts of this vast country, and awaken in the soul of America a thirst for the best in music. Radio should teach the people to learn to love good music. There can be no cultural progress so long as people are given only what they already enjoy. Let us teach the people to want something which has not yet been given them.

"For the most part, radio is considered by everyone as merely a medium of entertainment. And this entertainment is almost entirely music. This is a desecration. Music



MAY SINGHI BREEN AND PETER DE ROSE

Who have been heard from station WEAJ and others in banjo and piano duets. Miss Breen is a banjo player of striking talent and is well known to radio audiences. The insert shows the head of a banjo she has used in many radio studios with its signatures of radio favorites, including Jack Yellen, Doctor "Billy" Axt, and George Gershwin

should be a divine service to humanity. It is a pleasant thing when enjoyed as a mere pastime. But with every mental uplift, there must be a consequent struggle, and in order to comprehend the divine beauty of music, one must be willing to make the sacrifice of laboring to understand.

"One of the beautiful possibilities of radio, as I see it," continues Mr. Fritz Reiner, conductor of the Cincinnati Symphony Orchestra, "is to teach the fundamentals of music to the people. Americans have plenty of sentiment; they are not cold blooded. Their only drawback is that they do not know how to express themselves. Teach them the fundamentals of music and the genius of the nation will assert itself. When the whole nation loves good music it will pay for good music and thus afford an incentive to its youth of talent and intelligence."

Mr. Fred Smith, director of station WLW gathered these interesting ideas from Mr. Reiner, who is accepted as one of the outstanding symphony conductors now in America. WLW has done much in furnishing good music to its listeners. When the new long range station of WLW was opened, Mr. Reiner had charge of the dedication program, when he conducted a special concert with an orchestra of fifty picked men from the Cincinnati Orchestra. At other times, his Orchestra has been heard from WLW.

Other stations are known for the good music on their programs. Station KSD of St. Louis has the record of broadcasting every symphony concert of the St. Louis Symphony during the past season. The Detroit *News* orchestra, a permanent part of the studio staff of station WWJ, is composed of members of the talented Detroit Symphony Orchestra. Station WEAJ, of New York has broadcast regularly the concerts of the New York Philharmonic Orchestra. The good music that Mr. Reiner hopes American listeners can hear is being sent out from various parts of the country, though it has to force its way through a blanket of jazz. It is the contention of many that enough good radio music is being played now so that the taste of American listeners is slowly being raised. More will be said of this later, however.

Broadcasting, Canadian Style

IT IS bad enough," someone remarked, with what was probably a vocal twinkle, "when one listens to a Floridan or a Californian sing the praises of his climate to a

small group, but when they buy radio stations and, in a manner of speaking, tell the world about it, the situation becomes serious." Good residents of Florida and good residents of California have bought broadcasting stations, but it must be recorded that they are reasonably restrained about the climatic merits of their communities.

But now are the Canadians fallen from virtue. CKAC, the excellent station of *La Presse* at Montreal, cannot withhold the attractions of the Province from a listening world. On their program for the two weeks beginning May 30th, appeared the following legends.

June 2: 8:30 P. M. Talk on Attractions of Province of Quebec

June 6: 8:30 P. M. Road reports; talk on the attractions of the Province of Quebec

June 9: 8:30 P. M. Talks on the attractions of the Province of Quebec. Road conditions reports

June 13: 8:30 P. M. Studio program; talk on Quebec attraction.

Sir Robert Falconer, President of the University of Toronto, has been giving a series of lectures before English Universities on the general subject of Canadian and American relations. One of the interesting points that he made was that Canada and the United States were closer in some respects than England and Canada. This is due, Sir Robert thinks, to the fact that Canadians read American magazines and hear American broadcast programs, both prepared for purely American consumption. A Rotary Club speech from some Middle West city is heard by a group of far-off ranchers in distant Canada. So, thinks Sir Robert, do American ideas penetrate Canada.

But now the American leaven is working, and listeners on this side of the border are getting some of their own medicine. A new and amusing form of reciprocity!

General Dawes as a Musician

SINCE Charles G. Dawes, Chicago banker, attained world wide, and later national fame through his feats of statesmanship and politics, broadcast directors have discovered that this picturesque and extraordinary person is a composer of parts. Several of his compositions including his "Melody in A Major" have been heard by radio listeners. Which calls to mind the Washington experience of Mr. Heywood Brown, the genial columnist of the *New York World* who inquired of a politically in-

clined woman of his acquaintance how the General ranked among composers.

"Does he write good music?" asked Mr. Broun.

"That all depends," the lady answered, "on whether you are for or against changing the rules of the Senate."

When Central Americans Overhear the United States

AMERICAN broadcasting stations are picked up throughout all the Central American republics, and programs are enjoyed as a rule, though there has been some complaint regarding the quality of music," reports R. A. Lundquist, chief of the electrical equipment division of the Bureau of Foreign and Domestic Commerce at Washington, after a recent trip through that territory.

"On the other hand, in several cases, radio fans who had instruments of sufficient selectivity and range to choose between American stations, commented favorably on this point, saying that they were surprised to note the quality of music received from small towns where the programs were given by local talent. This was especially true of the Middle Western states which are apparently in some sections picked up more readily than are those in the East or far West."

Those who use care in tuning and pick up some of the smaller mid-West stations will hear good music, well played. In these localities, there are numberless amateurs of the voice, piano, and violin, whose names never appear on great concert programs, who are heard over the radio from stations the length and breadth of the country.

"We have used the home type of music and program at our station," said Mr. Henry Field, of Shenandoah Iowa, owner of station KFNF, "partly because it was the easiest thing for us to do, and partly because I had the definite opinion that people were hungry for the home type of music. We feel that there is a big demand, which many people do not suspect, for simple, wholesome, old-fashioned music. I find that a surprisingly large number of listeners of all classes are very tired of cabaret music and would like to have more of

the old home-town stuff." Mr. Field was addressing one of the committees at Secretary Hoover's annual radio conference at Washington, last October. He continued, "I have a letter in my pocket from a prominent man here in Washington who listens-in regularly. Both he and his wife are small town people. It would be interesting to hear their comments on the cabaret type of music which they get from so many stations, and how "it seemed like a breath of air from the prairies" to hear Gospel hymns over the radio."

Fewer jazz orchestras and a bit more of what may be called standard music from broadcast stations would meet with great favor from the public, if

existing signs may be taken as any criterion.

Broadcast Miscellany

ONE of the two women governors in the United States was heard over the radio from station KOA, Denver, some weeks ago. She spoke on "Cheyenne Frontier Days and Wyoming of To-day." Listeners were much interested in her description of the change in her native state.



TEN EYCK CLAY

The new director of the wgy Players. Station wgy was the pioneer in securing and presenting radio plays and has found that radio listeners favor short plays, prepared especially for broadcasting

SIGNING off," that phrase heard from every broadcaster at least once during the day's program, is to be abolished at station WLW. Some "appropriate quotation" will be given instead, and finality achieved by "Good night." The news bureau of WLW offers as a sample quotation: "Great thoughts, like little deeds need no trumpet; good night." "Signing off" is a hold-over phrase from the telegraph side of radio, and, like the use of call letters to designate stations, has little to do with broadcasting. We think this is a step in the right direction, but why complicate the closing with a sententious quotation? Isn't a simple "Good night" enough?

LISTENERS are constantly on the search for an up-to-date list of broadcasting stations, their wavelengths, power, and call signals. One of the best of the many books

we have seen is *Dunlap's Radio Call Book*. In addition to listing all the radio broadcasting stations of the world, the book contains their slogans, and is kept up to date by a monthly supplement containing changes and corrections. It may be secured for \$1 from Dunlap's Radio Call Book Service, Box 88, Flushing, New York.

CORRESPONDENCE from controversial-minded readers of this department is invited. We are anxious to present the opinions of readers on broadcasting and its problems, and it is our hope that this department will be considered a forum, open to any one who has something to say and says it with clarity and intelligence. Correspondents are asked to do us the courtesy of signing their full name and address, which will not be used if they so request.



THE MECHANICS OF A RADIO PLAY

In operation at WGY, when the WGY Players put on "Rip Van Winkle." Ten Eyck Clay, director and leading man of the Players is at the microphone as Rip. Frank Oliver is pouring water through a sieve to give the effect of rain. In the background are the thunder sheet and the wind machine. The radio Players seem to be enjoying their share of the performance as much as the listeners, which is putting it mildly

The Revolution in the Art of Teaching

The Long Arm of Radio Is Bringing the Best from the College to the Remotest Districts—What the Public Wants and How Their Wants Are Being Met

By FREDERICK P. MAYER

THE long trips on cold trains in winter, the meals in poor restaurants, the leaving of work and papers to do what seemed of doubtful permanency are things that only the professor who used to give lectures to small groups in various communities can understand.

The university extension course was given in the high school auditorium of some small town where there were enough high school and grade school teachers and enough interested club women to make an audience of perhaps a hundred. To this small group, the university sent out, at a heavy financial outlay, a part-time "extra-mural" teacher who traveled to the small town from his school, delivered his lecture to the one hundred teachers, and went home again—with little done for the outer world of popular education and little done for himself and his school.

But radio is changing all this. The professor of to-day prepares his lecture for his radio class with greater care than he gives to the class lecture on the campus. His audience may include professors in his own field who are eager to check the work his school is doing; he knows that business men and high school boys, men in barber shops and clubs are his class.

Having prepared his lecture, he goes to the broadcasting studio, that curious muffled room where his voice frightens him by meeting him as he walks in. The room is draped with gray cloth, and there are wicker chairs, a desk, and floor lamps. And reasonably inconspicuous, are the ever-faithful microphones, from which you hear the lecture on "Why Read Fiction?" or "Political Parties from Washington to Jackson," listeners-in from Florida to Washington, and throughout Canada eagerly tune-in.

The light flashes; the man at the announcer's desk calls "all right" to his friends at the broadcasting station; they return the signal; he flashes the "Silence" sign at the desk, and opens the line. The air is ready. The instructor begins after the University announcer says, "Good evening! This is the University of Pittsburgh studio of station KDKA, East Pittsburgh, Pennsylvania. This evening, Professor Smith, of the English Department is going to talk to you about 'The Contemporary Novel.'" Then a slight pause, and the Professor begins his talk. This is what has been occurring regularly at KDKA in coöperation with the University of Pittsburgh, and is true of other broadcasting stations in many parts

Giving the Teacher the Air

IS ANOTHER experiment with the possibilities of radio. Mr. Mayer does not attempt to tell what every university and college in the country has tried to do with broadcasting, but he does tell what has been in progress at Pittsburgh. Columbia, Rensselaer Polytechnic, New York University, Kansas State Agricultural College, and many others for some time have been broadcasting subjects gathered from their class rooms. And many broadcasters have presented talks given by members of various college faculties. There are many who feel that radio can never lend the personal contact that the University has always felt to be a necessity for instruction. But there are others who are quite willing to let radio do what it can to broaden the scope of higher education, and some of the experiments seem to prove that radio has indeed a field here. It is maintained by some that broadcasting is more a medium for entertainment than instruction, but those who are in charge of the various "air courses" undoubtedly have something to say about that. In an early number, RADIO BROADCAST will publish an article by Major J. Andrew White, the famous descriptive broadcaster, which humorously shows that radio education is—well, not as effective as it might be.—THE EDITOR

of the nation. Some universities have erected their own broadcasting stations to give "air college courses." Notable among the colleges to try this experiment in education is the Kansas State Agricultural College whose call, KSAC is known to many.

At Pittsburgh, extensive plans have been made for bringing the learning of the college class room to the radio listener. A year, or more ago, the University of Pittsburgh, through its committee on radio extension, discussed ways and means of beginning radio extension through its own studio. Conferences resulted in an agreement of mutual responsibility for the new venture. The University agreed to furnish the studio and to appoint a full time radio manager whose business it would be to arrange programs of consistently high merit. The Broadcaster installed transmitting apparatus which cost several thousand dollars.

The opening night was an important event for the radio world. There had, of course, been university studios in operation before KDKA and "Pitt" began, but none had consistently pledged themselves to serious extension work. University and commercial studios had, before this, differed little in aims.

The program opened with University songs by a University quartet. Then Mr. H. P. Davis, vice president of the Westinghouse Company, delivered the first address, and turned the studio over to the University for its use as an added means of bringing knowledge and new ideas to the people it hoped to serve. Dr. John G. Bowman, Chancellor of the University, followed Mr. Davis with a brief talk of acceptance, and outlined the plans and aims of the program of popular education. Mr. Marcus Aaron, President of the Board of Education of Pittsburgh, then told how the people in Pittsburgh had a new means

of education advancement put into their hands. At the close of the evening, the University was launched upon its experiment, with Miss Helen J. Ostrander, manager, in charge of programs and speakers.

THE FIRST YEAR

THAT year was a busy one for the new studio. Two ten-week courses, one on literature, by members of the English Department, and one on party government, by members of the History, and the Political

Science Departments, were broadcast on successive Mondays and Tuesdays. During the first month of lectures a very encouraging number of appreciative letters were received by the University, and so the University added extra lectures by members of its staff.

There were talks about trees and wild flowers, weeds, birds, fish, and the stars. It was amazing to see how great a demand for nature talks there was in the industrial radius of Pittsburgh, a section that is normally listed as interested only in steel affairs and the making of rails. Not only boy scouts, but also men and women

wanted to know more about plant and animal life and the wider world round about. Broadcasting educational talks, the University believes, is one form of radio work that can be made to have genuine value as a means of getting popular education to more people. The days of the educational phonograph record, the correspondence courses, and the extension courses are threatened by the new method of giving course instruction to thousands who want it and find it hard to get. The demand for outside readings and questions for study and printed forms of the lectures made it necessary to print radio publications which were distributed at small cost to listeners all over the country, who gave some of their winter

The Future of Radio Education

WHEN radio has settled down to a constructive basis, instead of being, as now, chiefly a medium for light entertainment, educational courses will take on a more important aspect. No doubt, broadcast directors would hesitate to put on a musical lecture that lasted more than an hour. They would see, in their imagination, thousands of impatient listeners, tuning-out to a more congenial attraction. Yet, they might use their imaginations to realize that those who interest themselves in these education courses would be more numerous if they thought that the paying of a fee of one dollar, for example, for literature and examination papers would include an hour's instruction weekly.

Perhaps, in time, we shall have certain broadcasting stations given over wholly to educational programs. If this day comes—and such a thing is not unlikely—a course in musical appreciation, in literature, or any of the other educational subjects now put on the air will be more thorough than is at present possible.—JENNIE IRENE MIX, in "The Listener's Point of View," RADIO BROADCAST for February, 1925.

nights to pleasant reading under the direction of a university faculty hundreds of miles away.

THE POSSIBLE AND THE IMPOSSIBLE

THE universities which are experimenting with radio as a means of instruction do so with no illusions. The standard of the work done, the knowledge of the student's abilities, the supervision of study that a campus course or an old extension course can give is indispensable for serious study of a high academic rate. It is manifestly impos-

sible to give university credit for radio study. As yet, no means has been found to check up on work done by radio students. A radio course can never take the place of a college year spent on the campus.

Universities that are giving radio courses seem to believe that they can give the means for individual self culture to people who are interested in having new ideas, no matter where they live. There are men and women so far from the contact of intellectual forces and the opportunities of libraries and lectures, that new facts, new thoughts about their world and the things that are going on in politics, and letters and science, cannot help but be a means towards happier living in an isolated area. The radio can inspire the same interest in social and political progress that a good magazine, clearly written, can give. Indeed, the radio can do more. It gives the same material as the magazine does, but it gives it in a more immediate form. It is easier to listen to a man speaking than to go

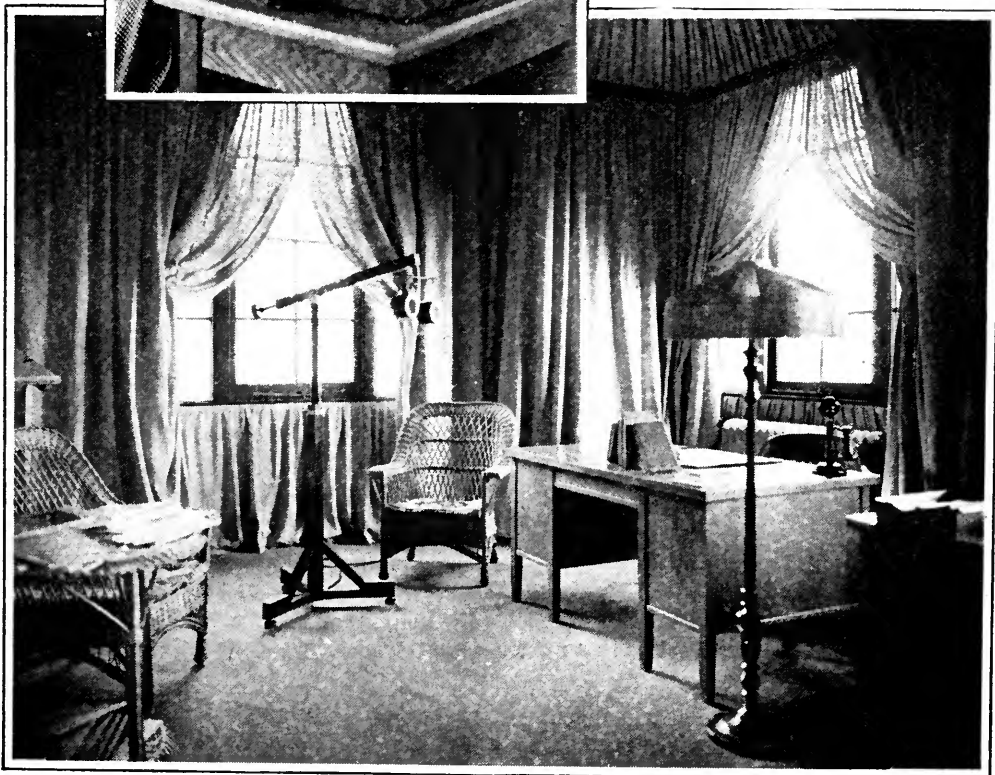

BROADCASTING HEADQUARTERS OF THE UNIVERSITY
And Miss Mary F. Philput, radio manager for the University of Pittsburgh

to his book, provided that he speaks clearly, slowly, and with a sense of real interest in his subject. That is what the men at the University have had to discover. They must talk with more energy to a class that they cannot see than to one that is in the room with them, because the voice is their only chance of appeal. What applause is to a vaudeville rope climber, the presence of a flesh and blood class is to the teacher. He needs applause, and he has to fight the blankness of the microphone while he delivers his radio lecture. It is amusing to see a teacher stand before a microphone and wave his arms with his usual class-room gestures and find that they mean nothing to the silent microphone or to the man on the North Dakota farm who is wondering "why doesn't that chap talk so I can hear."

Is radio instruction reaching an audience that wants such help? As an answer to this important question, the University could look only to whatever letters came in. But would anybody care enough about political parties and the contemporary novel to write even a post-card! And if they heard the talks, would they like them? The answer came almost immediately. The files of the radio room are stuffed with letters from listeners from Canada and thirty states, including Nebraska in the West, Minnesota in the North, Louisiana in the South, and every state on the Atlantic coast. Among the writers are lawyers, dentists, physicians, bankers, business men and women, high school students, farm men and women, teachers, housewives, college students, club-women, and grade school children.

Of course, there were complaints. The University expected them, more than came in. But not one letter of objection to the idea as a whole appeared. All the writers liked to listen to the talks, but they objected to big and little things in the way the talks were given—and mostly with justification. One man objected to the pronunciation of the word "vaudeville," and he was right. One man said the speaker talked too fast; he had sat by his typewriter and tried to take down the names of books to read, and the speaker rushed through them without a chance for a note. The lecturer of that night, who was accustomed to dumping masses of material on college classes who could go to a library later, spoke more slowly on the following nights. Another writer asked if we wanted any one to hear what we were saying. If we did, would we talk louder? And we did. Several wo-

men who were normal school graduates and wanted college work insisted on getting credit for the lectures; they asked for examinations and papers to be graded. That request, much as the University wished to help, was refused.

WHAT THE PEOPLE SAID

APPRECIATION for the new thing came in all forms, from the serious to the funny. The people who wrote ranged from men and women with college degrees to farmers who had little advanced schooling, and yet thought it was worth their while to say that they liked the programs. Stationery ran from beautiful sheets of embossed personal writing paper and bond sheets of discreet banking houses to the printed splash of an Iowa seed store, and the pencilled scratchings of an old man who found the "radio was something to look forward to once a week."

A letter came from a friend of a young man sick with tuberculosis. He asked for a reading list that might "be of some benefit." The boy wanted "in that way to educate himself as much as possible from this source." Needless to say, the English department got busy. A group of students from Wittenberg College were gracious enough to want the lecturer to know that they were taking a course in the novel with him. A club woman from South Carolina found that the lectures helped her in preparing a program on the contemporary novel. A woman on a New Hampshire farm, who had taken a course in the novel with Katherine Lee Bates in her college days, said "I now live on a remote farm, and I am especially pleased with your proposed course, What that means in terms of days on a farm, no mere city reader can quite understand."

A mother wrote for the novel bibliography. "We are desirous of putting the best of reading matter before our four children."

A man from Philadelphia wrote to the University and asked for an outline of the lecture, because he missed part when his daughter ran a splinter into her finger, and he had to leave the phones and help. Unfortunately he did not give his address. A directory searcher gave us his address, and the following letter is the result of this correspondence.

Did I hear the announcer say to send 10 cents for the program? My daughter run a splinter in her finger so Dad missed part of the broadcasting. I had to get that splinter out. Well I am one of KDKA listeners in and must say I am very much interested in education and if nothing prevents me I will be a regular listener. In Phila. we have a lot

of single circuits so we who are anxious to learn will have to make the best of it. Well Mr. Manager it is well worth trying for. When you go fishing some get little ones others get big ones so I hope I will be able to get all that is possible out of your generosity.

That is the sort of friendship the University of Pittsburgh feels glad to have made; it is worth much to the people who are wondering whether or not radio pays.

A gentleman from Pittsburgh wrote,

I am an invalid who is *getting well*. I have had a wonderful sense of help by radio in listening to the good sermons, prayers, and lectures. I have been ill many years and have spent many years in bed with too much weakness to even listen-in. Radio opens a glorious avenue to me. I love the fairy stories for children and the bed time talks. . . . Now I see that light and health are coming. This beautiful spring day—all Nature simply singing—I had to write you this personal side of things, it seemed. Pardon me, but you will be glad to know it. You asked so kindly what we would enjoy. I would enjoy bird lore and nature talks, *woods* and out-doors. It is so lovely to hear word pictures over the radio. I imagine I am living it. One enters with much more intimacy into the mind of the speaker when there is nothing to divert. I enjoy the literature professors. . . . I enjoy your voice so much.



DR. JOHN G. BOWMAN

Chancellor, the University of Pittsburgh. Radio college courses have been tried under his direction and are meeting with a favorable reception according to statements of the University authorities

And this is another of the letters the university studio is happy to have on file.*

WHAT THE PEOPLE WANT

AMONG the courses asked for by listeners were lectures on ancient and medieval and modern history, biology, banking, advertising, and salesmanship, musical appreciation, and history. Radio teaching will mean a busy life for the University if it tries to meet suggested demands.

An alumna in New York felt that she was back on the campus again when she heard the English lectures, and asked for a series on Child

Psychology. "Of course, I realize that any work of this kind must, of necessity, be very superficial but it certainly has some value dependent largely upon the amount of supplementary work that is done in connection with it."

So the letters came in. Each mail brought new acquaintances from new places. The first year of University Extension by radio was a successful experiment. It is, as yet, only an experiment. What science can do to make radio reception easier and more certain, what the University can do to give more and better lectures, what the listener-in can do in the way of preparation for what he reads, make

the trio of factors upon which success in popular education depends.

Some people—as the hundreds of letters show—are getting pleasure and profit from the work. But can it hold its own place, this educational program, in the face of dance music and comedians? Or is the percentage of fans who do not want this, large enough to make the radio broadcasting companies reject educational features because they are unpopular with a majority? Only time will tell.

The best letter of appreciation for serious programs came to the broadcasters from the pastor of the

Point Breeze Church, to whom the following letter of thanks was addressed.

Monday

To the Minister of the POINT FREE PRESBYTERIAN CHURCH
PITTSBURGH, PA.

DEAR SIR:

Last night while making for port off the Montauk Point Light, I was listening in on my radio which I installed on the last trip to the States, and the first which came in was the music and then the rest of the service at your church. I write this to you for the purpose of calling your attention to what I call a study mixed mentality. When I got the music

the deck hands as well as the dog watch was in the Cabin all hoping that the "Darnation thing would work" and when I said I had a church service on the air they all gave a great guffaw and laughed heartily. After a time the grins, and horse jokes laid off, and the faces of the swabs all took on a serious look and after a time, I said well I guess thats enough of that stuff, and much to my surprise, every damn one of them roared out, No leave it alone and lets hear what that stuff is all about. I held the service all the way to the finish and the trouth is that they all was pleased when they had the whole of it as they said it was the first time they ever had anything of that kind served to them, except when I read the service for the dead at sea, and they all admit I aint great shakes at that. Had two to slide over the side on the last trip. The mast hands told me to get in on it next Sunday, but since we clear for South Africa Friday, I am afraid we will be out of range, but at that we will be listening in and if you are on the air we will get it from Hell to Breakefast. The funny thing and the thing that struck me as so queer is that most of the square heads that I have aboard hasnt been inside a church since they was born, and

now damned if they aint talking about the church they heard on the radio while they are unloading cargo, and I can hear 'em through the port. Next Sunday talk strong, and slip over something about sailors, and I believe you will be making church goers of a lot of swabs that aint much good and never will be. Muck oblidged for your music and preackin Sunday, and say I want to tell you you have some singers, and especially the first saprano who was nearest the speaking makeine her voice come over like a bell. Heres hoping we can get you all the way cross, and more power to you for your favor. Excuse me taking the liberty of shooting all this off to you but I thought as how you might like to know what kind of a lot know nothings at least some of them you have for your services.

Yours truly

(Signed) JOHN CLAPMAN
Master
Barkentine *Plymouth*
Registered Lloyds
London

p. s. Your preaching is good Its the first I heard in eighteen years and I enjoyed it.

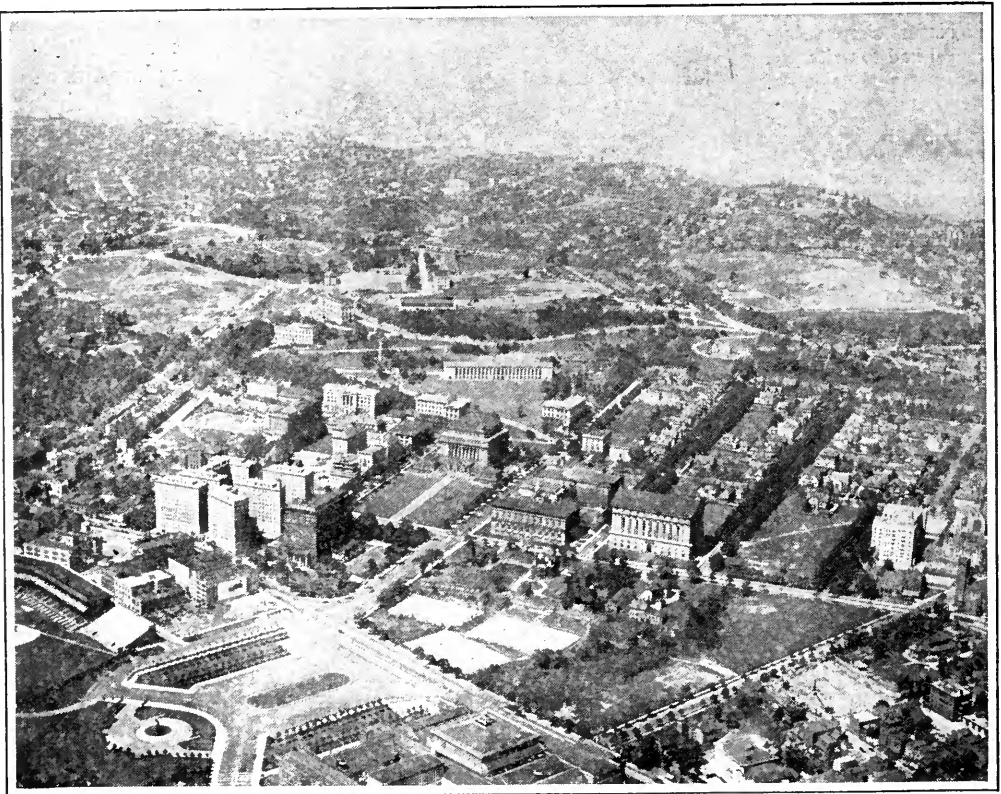

AIRPLANE VIEW OF THE CAMPUS, UNIVERSITY OF PITTSBURGH

The large open square with the tennis courts, lower right, is the fourteen-acre plot which is the site of the new University of Pittsburgh "Cathedral of Learning," a fifty-two story Gothic building. Plans are already under way for this structure. The radio studio of the University is located in a room in one of the smaller buildings near the center of the campus. It is connected by wire to the broadcasting station

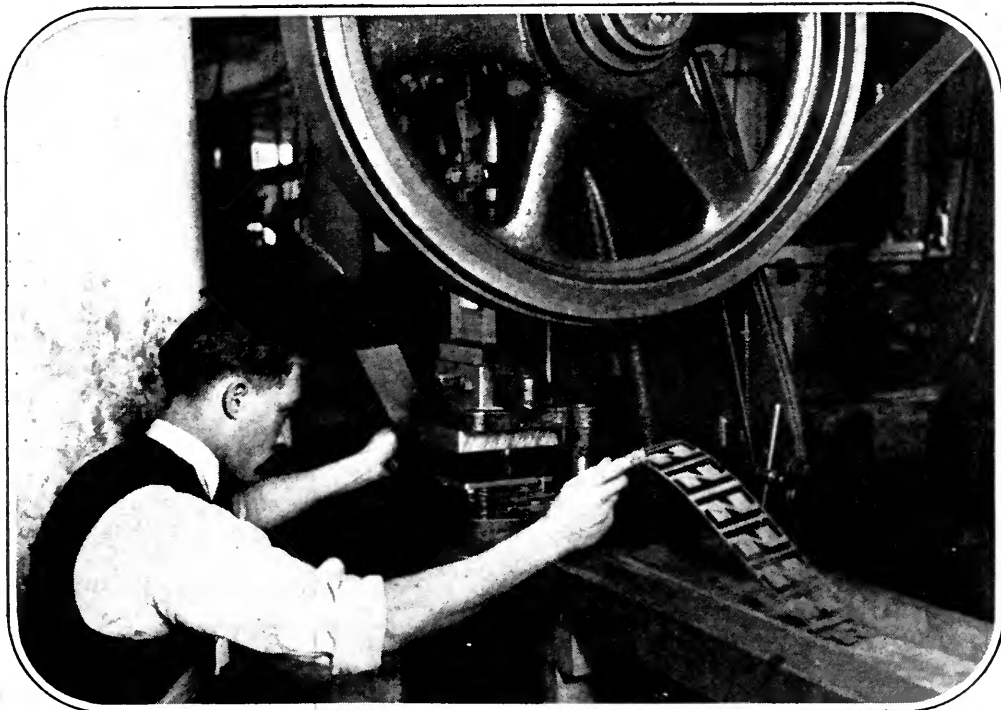

STAMPING OUT THE STEEL LAMINATIONS

For audio-frequency transformers. Transformers, like all other radio parts, are made in very large quantities and special machines have been built for their manufacture

THE MARCH OF RADIO

BY

J. J. Morecroft
Past President, Institute of Radio Engineers

Why the Radio Industry Will Not Be Revolutionized

ONE of the prominent radio manufacturers recently expressed his opinion of the phrase, "revolutionizing the radio industry," "coined by some business man with the idea of preparing the public to buy the set he had in process of manufacture. The term has been used by many radio publicity writers. They undoubtedly think that their use of the expression would make their task easier by giving to the buying public the idea that everything so far accomplished in radio de-

velopment was to be scrapped in favor of some wonderful device which they alone could produce.

"The well meaning chap who coined that infernal expression" says Edward Jewett, of Detroit, "did radio an ill turn. It has raised false expectations and has cut the radio season short by about three months. Two years ago the peak of the radio season was in April, a year ago it was in February, and this last year it came around the Christmas holidays."

In Mr. Jewett's opinion, "the principal

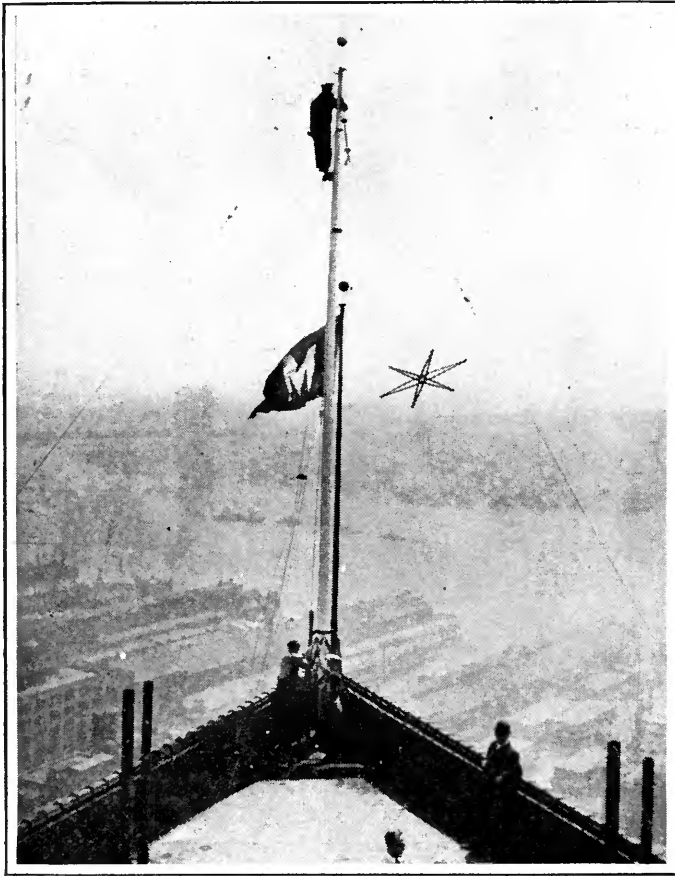

INSTALLING A NEW ANTENNA FOR STATION WCG

The New York coastal radio telegraph station of the Independent Wireless Telegraph Company. Many ships in the transatlantic and coastwise service communicate with this station, sending and receiving weather information and commercial messages. This station has a power of $3\frac{1}{2}$ kw. and will use wavelengths of 600, 706, and 2100 to 2400 meters

contributing cause was the wide circulation of the expression 'revolutionizing the radio industry.' When people heard it they immediately hesitated, as much as if to say 'If such wonderful things are going to happen, we'd better wait a while.' Most of them are still waiting and if they are going to wait until the industry is revolutionized, they will be waiting forever."

This opinion is a sound one and unquestionably founded on fact. A great many people actually have the idea that to-morrow a new set is to be put out which will eclipse anything at present on the market, and that the purchase of radio equipment obtainable to-day is a waste of money. So undoubtedly the apt phrase has boomeranged on the industry and made inactive a large part of the

prospective purchasers of radio equipment.

To one who has even casually looked over the development of radio during the past twenty-five years the idea of a revolutionary step is hard to grasp. There has never been any such step in so far as the technical progress is concerned. The Fleming valve, De Forest audion, and the concept of amplification and regeneration were all old in the art before the present radio public existed. And each of these came into being rather quietly; wonderful as they were, they inspired only moderate enthusiasm because those who appreciated their significance and value were so few. The super-heterodyne, conceived by Armstrong while working for the Government on radio development, and the neutralized amplifying receiver, first thought out by Hazeltine, Rice, and others, were both finished before the era of broadcasting even began.

If we look then for an epoch-making radio development during the past five years, the life of radio broadcasting, we really find

none. Improvements there certainly have been, both in parts and sets, but nothing which has "revolutionized" the industry. The thoriated vacuum tube filament was a great advance over the pure tungsten filaments, which had been generally used in radio tubes, but even thoriated tungsten is not really a revolutionary step over the oxide-coated filament, itself older than the radio industry.

Probably the greatest recent advance in radio has been in the loud speaker and we all know that this development has been gradual enough; it has been evolution rather than revolution. A few scientists have, on occasion, been willing to announce to the press that they had conquered static, but even these venturesome ones are gradually retiring from the stage and by their silence rather

conceding that even static is to be conquered by diligence and well conceived steps rather than by any spectacular invention.

If one wants a radio set he should go and

buy one now. The heralded revolution in the radio industry probably will not materialize.

What is the Radio Receiver of To-morrow?

NO GREAT single step in radio progress is likely to be made in the near future. But to counteract the impression that radio is stagnant, let us look at to-morrow's radio receiver to see what we shall be buying a year from now.

The one respect in which the set of the future will outrank that of to-day is in quality of reproduction. At the transmitting stations, hundreds of thousands of dollars are being spent in improving the quality of the radio signal emitted. Scores of the very best radio engineers in the world are analyzing each minute step from the voice to the antenna, taking pictures of the currents in the various circuits and comparing them with theoretically correct forms. Exact knowledge is possible in this end of the radio channel because of the money and talent at work on the problems.

Has the reproduction of sound in the home, from the radio signal sent out by these high

TERRITORY OF HAWAII

PHOTOS SENT BY RADIO HERE TO NEW YORK

Radio Corporation and Army Send Pictures Over Land, Sea, Successfully Greatest Distance Ever Spanned: First Achievement of Its Kind

NEW YORK, May 7
The Radio Corporation

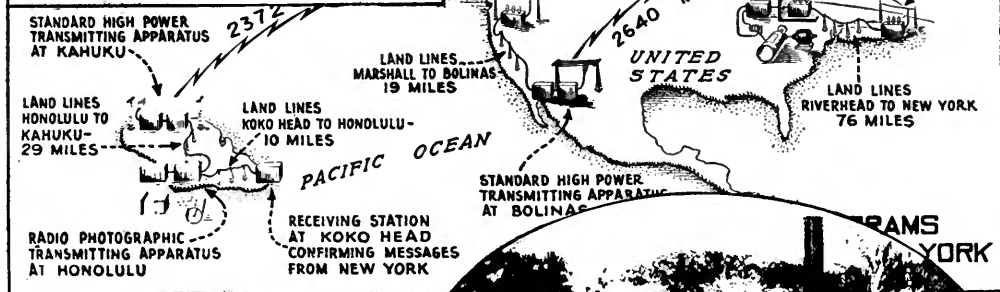

PHOTOGRAPHS BY RADIO FROM HAWAII TO NEW YORK

The map shows the number of electrical transfers the original photograph sent from the Radio Corporation high power telegraph transmitter at Kahuku, Hawaii had to undergo before it reached New York. The insert above shows how a photograph of a section of an Hawaiian newspaper looked after being flashed through the ether to New York. The lower insert is a radio-transmitted photograph of soldiers on Hawaiian duty at mess.



At the time this experiment occurred, May 7, 1925, the Army-Navy "war game" was in progress, and an excellent opportunity was afforded for showing the value of that unusual kind of radio communication

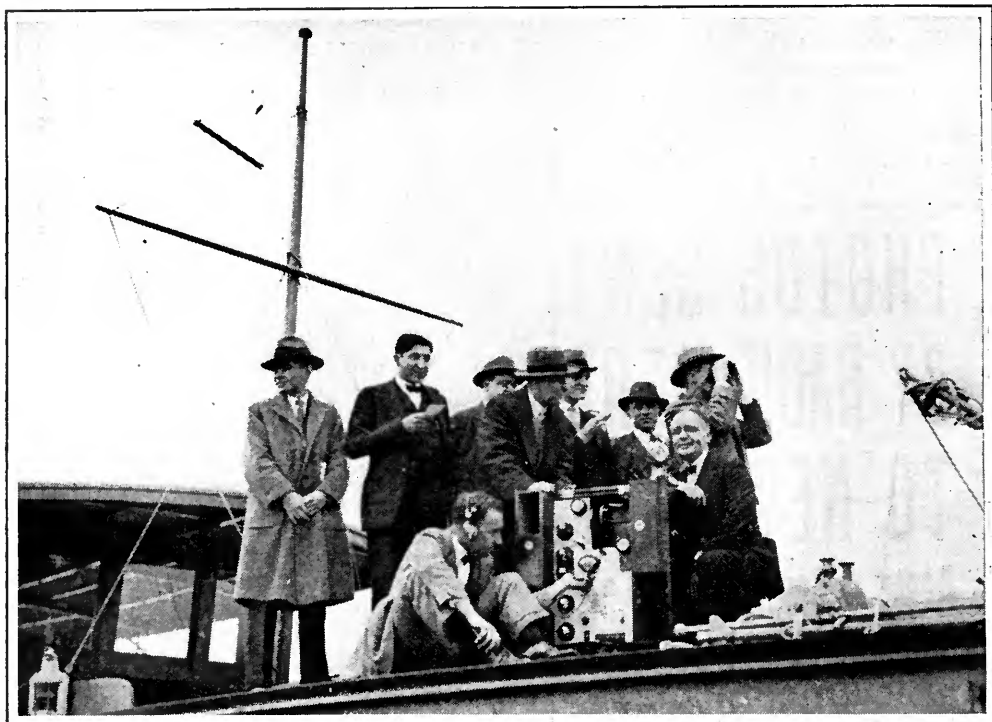

WHEN WJZ WAS PORTABLE

The short wave transmitter aboard the yacht *Elco* which was used as floating broadcasting headquarters to report the Childs cup rowing races between Columbia, Princeton, and the University of Pennsylvania. A similar arrangement was used to broadcast the rowing races at the Poughkeepsie Regatta, late in June. A receiver on shore picked up the short wave signals of the station, announced by Major J. Andrew White (at the microphone in this photograph) and thence they were relayed by wire to the main wjz station

priced transmitters, kept pace with their development? Certainly not, and here is the place where progress, is to be expected. Ask any one with a musical ear if a radio orchestral rendition is as pleasing as the original and the answer must now be in the negative. The response of the average loud speaker and amplifying set is woefully lacking in faithfulness of reproduction. Few radio listeners turn around in surprise to find that their friend, who is talking over the radio, is not in the room with them—that a loud speaker is sending out (or trying to send out) the well known voice. And until such surprises exist we can surely say that here radio is to be improved. We do feel that great progress has been made, but still more remains to be accomplished.

In spite of the slowness of its appearance we believe that the completely batteryless set is sure to appear. It is reasonably close to accomplishment for all except the "distance hound," who may be bothered by the slight hum which may exist sometimes in these sets.

Improvement in quality of reproduction, besides keeping the loud-speaker manufacturer busy, entails on the set manufacturer a burden which he has not so far assumed. To get good quality, we must use in our sets at least one tube of much greater output capacity than the present receiver tubes possess. A small-power tube of from five to ten watts rating, must be put into the set to operate the loud speaker if the great variation in power of the voice or orchestra is to be truthfully followed. To operate such a power tube, several watts will be required for the filament, and the plate supply must be of a much higher voltage than can be efficiently obtained from batteries. This development, sure to come, will hasten the time when the lighting company's power is used completely for the receiving set.

For some time there will be many cases, of course, where batteries must continue to be of service; there are millions of homes in America which are not electrically equipped. This radio change from battery to house wires will also be gradual, not revolutionary.

The day of the nine-dial set (of which one of our friends boasted some time ago) is assuredly doomed. Much has been written about the one-dial set. Possibly with refinement in mechanical design and manufacture, it will be made sufficiently efficient to create a market for itself. It is much easier however, to make a two-dial set operate efficiently than a one-dial and as we have two hands which permit simultaneous adjustment of two dials, two controls seems reasonable and justified. The average listener probably prefers two dials to one. With two dials, the adjustment is easy enough, and with one the three-year-old child could adjust the radio outfit as well as Father. Such a situation will probably not be encouraged by the older member of the family—he would lose too much prestige.

The purchaser, who acquires to-morrow's set will probably acquire an outfit with this gradually improved quality of reproduction,

greater freedom from battery trouble and easier adjustment. Improvements in the set's appearance, necessarily costly, will come as the buying public shows its preference for the art type of receiver.

The Radio Receiver of the Victor Company

THE Victor Talking Machine Company has finally entered the radio field. Said a representative of the company:

We have been urged by every known means to manufacture a set of our own. There are many reasons why we should not do so. First, the men and women who work in our factory are skilled in the delicate assembling required in the manufacture of talking machines. It would take a long time for them to develop similar efficiency in the assembling of radio equipment, a process which would be profitable neither to us nor to the public.

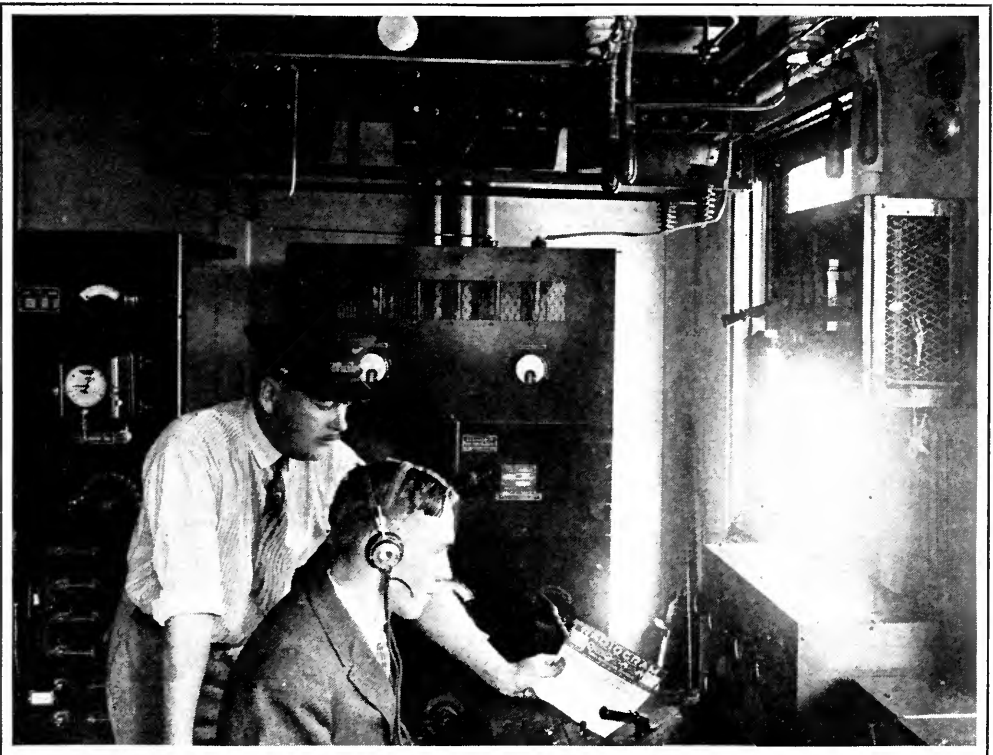

THE RADIO ROOM ON A GREAT LAKES PASSENGER SHIP

Radio is being modernized on the Great Lakes and tube transmitters and receivers installed. This is a corner of the radio cabin on the S. S. *Greater Detroit* which sails nightly between Buffalo and Detroit. This new liner of the inland sea is more than 500 feet long and has a passenger capacity of more than 1500. Traffic on the Great Lakes is growing heavier each year, both as regards number of ships and radio communication .

The Victor Company has completed an arrangement with the Radio Corporation of America to have super-heterodyne sets built for their talking machines. The engineers of the Victor Company decided to use this set, it was announced, after trying all the other sets on the market. A design of loud speaker new to this country is to be incorporated and it seems that this set, to appear in the fall, should prove most acceptable to the buying public.

Having thus allied itself to a certain extent with the Radio Corporation, the thought naturally arises: Will Victor artists broadcast next winter through Radio Corporation stations or through American Telephone and Telegraph Company stations? The concerts by the Victor artists were the bright spots in last winter's radio programs and everyone wants them continued, on the old lines if possible. When questioned regarding next winter's broadcasting the company's representative said:

Yes, the Victor Company expects to broadcast. It is neither our intention nor our wish to withhold great voices or great artists from the air. This phase of the situation, though, is not without its difficulties. A first requisite is that the artists be willing to cooperate and to cooperate at such compensation as may be commercially practicable. An offset to this condition is our own obligation to secure for them such reception as shall be worthy of their talents. But our plans are not yet worked out, nor can they be until a later date.

It will be remembered that the Brunswick-Balke-Collender Company has been for some time selling talking machines, with built-in Radio Corporation sets. Both talking machine companies will now put out RCA receivers. Mr. B. E. Bensinger, president of the Brunswick Company, states that the same special receivers furnished to the Victor Company will continue to be furnished to his company. He made the graceful gesture of complimenting the Victor Company on having followed out the same procedure as did his company the year previous.

When Great Men Speak of Radio

THE "electrical wizard" as Thomas A. Edison is frequently called, said in a recent interview: "Static can never be eliminated."

Perhaps this is so, but Mr. Edison's saying that it is so doesn't make it necessarily true. Many great men have been free in expressing their opinions on subjects they didn't understand. The American public apparently wants to believe that a man who has accomplished such great things as has Mr. Edison can give a reasonable opinion on many other things. So in considering Mr. Edison's views on radio, let us remember Mr. Ford's peace ship which was "to get the boys out of the trenches before Christmas." Mr. Ford didn't understand the war situation and

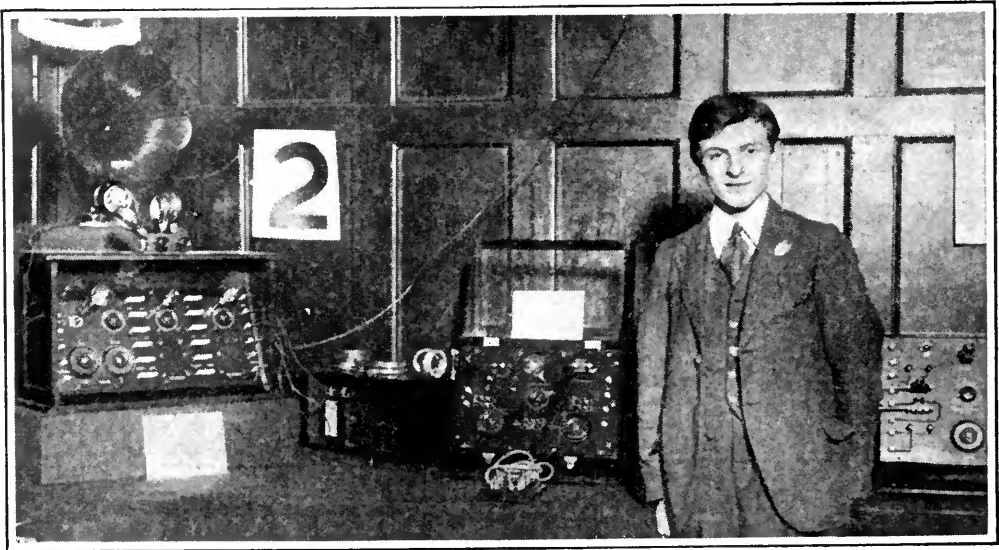

AN ENGLISH RADIO CONSTRUCTOR

Master J. H. Facer, aged 16, with his entries in a recent radio exhibition held in London

possibly Mr. Edison does not understand all the intricacies of radio.

Does Radio Need a High Commissioner?

THE idea of a unified control of baseball by Judge Landis, voluntarily vesting in him autocratic power in regulating all disputes which may arise, is a good example of an ingenious American plan to regulate and control a very difficult situation. The movie industry voluntarily put itself under the same kind of control. But of all the things requiring control of this kind, radio certainly stands foremost. In no field that we can think of is there more cause for disputes which will react to the detriment of the listener. To be sure, Herbert Hoover has shown great tact and diplomatic skill in arranging the past three international radio conferences, successfully bringing into line various conflicting opinions, both national and international, but his authority is by no means as powerful as that of the baseball Commissioner.

But our high commissioner idea has been so well thought of in Europe that radio there has just adopted it and all radio conflicts hereafter will be settled by one man who holds his position at the request of the various radio interests. Sitting in Geneva, where so many international movements seem to centralize, Mr. Arthur Burrows, an Englishman, will adjudicate all radio conflicts which originate in Europe.

This new international radio bureau, which Mr. Burrows heads, aims "to establish an effective link between the various European broadcasting stations, keeping in view the possibility of activities being extended to other continents; to defend all policies and measures affecting stations' interests; to centralize the study of all questions arising from the rapid development of wireless telephony and to initiate and further all efforts towards the improvement of broadcasting generally for the benefit of all nations both individually and collectively." From this statement it will be seen that head of the bureau automatically becomes the Landis of radio.

The bureau intends at once to interest itself in the question of radio relaying, a problem of ever increasing importance. More and more, as we see it, the tendency will be to do away with the talent of Main Street. We shall send out instead the most artistic performances obtainable. This accomplish-

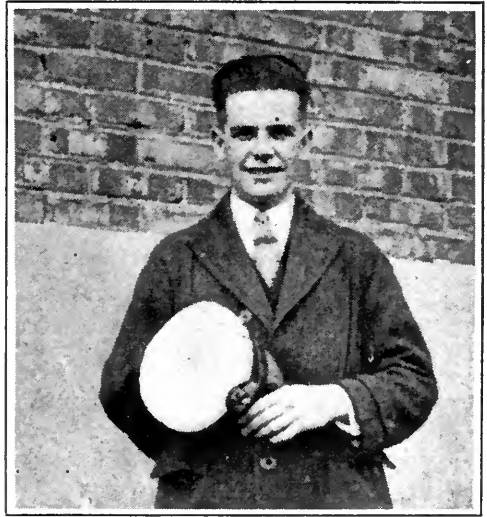

ROBERT M. FOSTER

Of Montreal, Canada, the radio operator aboard the Canadian Coast Guard ship *Arctic* which sailed for Etah, Greenland the latter part of June. He will experiment on 20, 40, and 80 meters, using the call VDM. Short wave experiments with Canadian and American amateurs and KDKA, East Pittsburgh were very successful during the 1924 expedition and more extensive tests are planned this year. The two ships of Donald MacMillan's Arctic expedition will also be in the same waters at about the same time. The MacMillan vessels are equipped with short wave telegraph transmitters also

ment of course is possible only by some scheme of relaying. The European bureau intends to be itself a direct channel for the interchange of programs, ideas, and regulation of all matters directly affecting radio broadcasting.

Radio Broadcast's Phonograph Receiver

THE two great centers of home entertainment are without question the radio and the phonograph. For the past four years, the radio set has probably usurped the domestic center of attention and the phonograph has had to take second place. But now that radio constructors are a little less eager to build every new circuit—being attracted to it simply because it is "new"—the attention of every radio user has naturally centered on the appearance of his receiver. It is assumed that he has found a type of set which satisfies his daily radio wants.

It has been the aim of RADIO BROADCAST to produce a radio receiver for home construc-

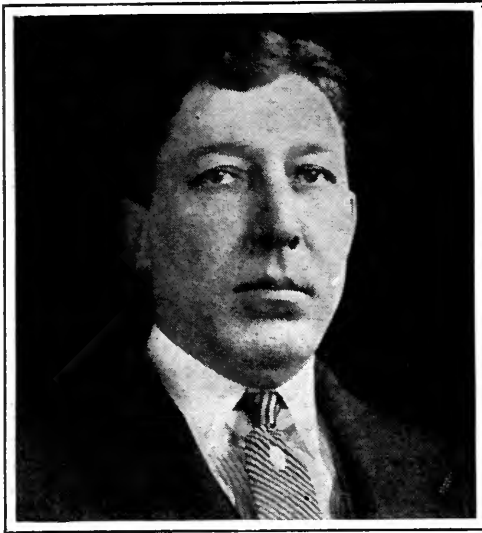

J. C. GILBERT

—Washington; Chief, Radio Market Service,
Department of Agriculture

“Progress in the field of radio broadcasting must include a systematic organization of weather, crop, and market reports and helpful agricultural information. There must be greater coöperation between all agencies concerned. I should like to see some general instruction broadcast to farmers about their radio sets, and how they should be installed and operated. The surveys which the United States Department of Agriculture made in 1923 and 1924 showed that the use of radio on farms is increasing rapidly. 370,000 radio sets on farms were estimated for 1924 as compared with 145,000 in 1923. About fifty per cent. of farmer-owned radio sets are home assembled. This is not extraordinary, for people on farms have much experience in making their own tools and equipment. There is no group or class of people in this country to whom radio means so much as to the farmers.”

tion which will satisfy the obvious requirements for practically every radio use: one that will deliver faithful service and one that readily can be built from standard and available parts. Further, we have tried to design this set so that it is easily made portable, if that be the desire, but chiefly to make it easy to install in the various types of phonographs found in American homes. These aims we are convinced we have attained in the Phonograph Receiver.

If the constructor has a phonograph of any one of the standard types which have been sold in such enormous quantities, the Phonograph Receiver can be built and installed with ease, and the phonograph will not be marred or made less useful in any way.

In fact, we feel that we have shown the way to make the phonograph doubly useful. To combine in one instrument the amazing breadth of entertainment the phonograph affords and the instant and vital daily entertainment that is the charm of radio is an accomplishment which should interest every one who sets store by his home and all that therein is. Our correspondence shows that our solemnizing the marriage of the phonograph and the radio has met with very widespread approval.

Reform Is Needed in Radio Advertising

THERE is no doubt at all that radio has a rather unsavory reputation with much of the buying public. We are continually asked about “what set to buy,” and find that the intelligent public believe little that is written about the merits of this set or that one. The reason for this disgust is at once evident to one who picks up an average radio magazine or newspaper and looks over the radio advertisements. There is apparently no set that isn’t the best, no condenser that hasn’t the lowest loss, no coil that isn’t the most efficient. Obviously they can’t all be the best. The reader naturally distrusts all of them.

The average radio advertisement is not an honest attempt to tell just what the apparatus will do, but rather a claim that it is better than that of any other advertiser. The “low loss” advertisements which have filled the magazine pages for months past are enough to demoralize any prospective purchaser. Each condenser has such low losses that this or the other laboratory found it impossible to measure them. Even if it were so, the fact remains that the purchaser could not tell the difference between perhaps twenty different makes, in so far as condenser loss is concerned. The losses in the coils (which always must be used with condensers) are so much greater than those of the condenser that any one of twenty good condensers will act practically the same in so far as strength of signals is concerned.

When it comes to complete sets, the situation is much worse. Were one to believe the extravagant claims made by dozens of manufacturers he could take a set home and after about ten minutes time spent in installation, hear practically any station he wanted to from one coast to another. But this isn’t the truth and many a purchaser has been grossly

deceived by advertisements interested only in immediate profit.

Isn't it about time that radio advertising settled down to a more reasonable basis? Extravagant and foolish claims will eventually only hurt a product and undoubtedly those advertisers who state sanely and reasonably what their apparatus is designed to do, and under what conditions, will in the end gain the confidence of the buying public.

Interesting Things Interestingly Said

SIR ROBERT FALCONER (Toronto; President, University of Toronto; in an address at Edinburgh University): "It is the theatre, the moving picture show, and the radio which are exercising the most penetrating and subtle influence upon the social standards of Canadians. . . . Every night thousands of young Canadians listen to addresses and talks directed to the people who live in the central cities of the United States. As immigrants from Europe have precisely the same character and outlook as those who have made their way into the United States pour into Canada, they will, through the constant repetition of similar ideas in picture, play, illustrated paper, and radio, soon be a type that will no longer be Canadian. . . ."

HUGH S. POCOCK (London; editor *Wireless World*): "The strongest ties exist between the radio amateur of this country and America. The first long distance communication employing short waves was achieved between Europe and the United States by amateurs, and although France succeeded in reaching America first, British amateurs quickly followed, and since that day, two-way direct communication has been permanently established with many friends on the other side. . . . It is impossible to overestimate the importance of the American section of the amateur fraternity. Their organization, the American Radio Relay League, is without parallel in the world. In no other country is such freedom extended to amateur activity or such use made of the facilities so granted."

DR. ARTHUR H. HAMMERSCHLAG (New York; president, The Research Corporation): "The greatest scientific advance in 1924 was in the field of communication—in radio and in radio photography."

CAMILLE FLAMMARION (the late French astronomer): "We might communicate with Mars by some other means than light and optics. Who can predict the future progress of science? Can we say that the Martians have not already tried by means of radio-telegraphic waves? Whence come certain unexplained disturbances of wireless

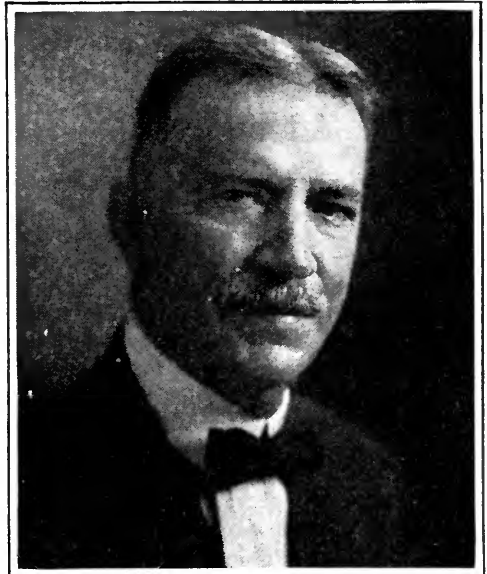

© Harris & Ewing

D. B. CARSON

Commissioner of Navigation,
Department of Commerce

"The public probably will continue to contribute to broadcasting liberally through the cost of equipment purchased. At present, there does not appear to be a more equitable way of distributing the cost while, on the other hand, such stations must have considerable advertising value, justifying the expense of operation where the owners of the stations gain their support through the sales of radio apparatus."

telegraphy? Perhaps from the sun, the effects of whose electric storms extend as far as the earth. Yet, for all we know, they may come from another source."

LORD DAWSON, OF PENN (London; personal physician to King George; in an address to visiting American physicians): "The central reason for the stress of modern life is our material progress. The movement has been so rapid that it has outstripped our rate of adaptation. The internal combustion engine, the telephone, and the wireless have so tuned up the modern man's mind that he remains in the same key when he is at work and when he takes his so-called play."

A. ATWATER KENT (Philadelphia; radio manufacturer, who broadcast from the *Los Angeles* on her recent flight over Philadelphia): "I hope there will be more broadcasting from airships. The people will, one may be sure, listen eagerly to brisk narratives of flight while the flight is actually taking place. Certainly those who were permitted to speak into the microphone on this first broadcasting voyage of the *Los Angeles* were thrilled."

For the Radio Beginner

Adding a Bulb to the Beginner's Crystal Set

A CRYSTAL receiver does not survive very long in these days of inexpensive vacuum-tube apparatus. But its short existence serves a purpose by initiating the beginner into an intelligent appreciation of radio elements and stimulates a desire for something better.

The crystal receiver described in this department last month, having served this creditable purpose, can be converted into a bulb set at an expense little in excess of its original low cost. The converted receiver will be more selective than before. This is because the resistance imposed by the crystal is eliminated. Resistance added to any tuned or resonant circuit broadens the tuning of the circuit. Also the receiver will be more sensitive and the signals more loud due to the superior efficiency of the bulb as a detector.

THE PARTS WE NEED

THE necessary parts for the conversion of the Beginner's Crystal Receiver described in this department for July, 1925 into a one-bulb set, are photographed in Fig. 1. The lettering is that conventionally employed in diagramming the various parts. The items and their prices are:

No. 1 Socket (receptacle)	.10
No. 1 Socket (screws and springs)	.10
No. 2 One 30-ohm rheostat	.25

No. 3 UV199 Tube	3.00
No. 4 Grid condenser, capacity .00025 mfd.	.10
No. 5 Grid leak mounting	.10
No. 6 2-megohm grid leak	.10
No. 7 Burgess small 22.5 volt B battery	1.22
No. 8 3 dry cells at 35c. each	1.05
No. 9 4 Binding posts	.10

\$6.12

With the exception of the tube and batteries, all parts were purchased in the 5, 10, and 25-cent stores. The cost of the crystal receiver described last month with the addition of a good pair of phones and antenna equipment was \$5.52. Thus the expense of the combination crystal-bulb set, including all equipment, is less than \$12.00.

A Course for the Radio Beginner

¶ On page 366 of RADIO BROADCAST for July, a simple crystal receiver was described which could be built from parts bought at the five-and-ten-cent store, at a total cost of \$1.82. The set will receive good broadcast signals from near-by stations. This month, a vacuum tube which will increase the receiving range of the set is added to that assembly.

¶ In this department also is begun a series of simple explanation of some of the simplest radio phenomena. What "detection" means is the subject of explanation this month.

¶ Additional help for the beginner is found in "The Radio Lexicon" which simply defines all the radio terms used in this article. "The Radio Library" recommends chapter and verse in good radio text books which cover more fully the same ground as this department.

¶ Zeh Bouck, one of the ablest radio writers in the country, is preparing this department. Mr. Bouck is an amateur himself of long experience and sympathetic mind and has passed through the stages of trial and error, of seeking and finding which all radio enthusiasts experience. He is known on the air and to readers of the New York Sun AS 2 PL, author of the column "What Are the Air Waves Saying?" and to readers of Boy's Life as editor of its radio department.

—THE EDITOR

THE CIRCUIT

FIGURE 2 shows how these simple parts are connected together and how they are wired to the crystal set described in this department last month, or to any similar receiver. The heavy lines on the right hand side indicate the connections between the new apparatus. One side of the grid condenser (C) is connected to the grid (G) post on the socket, and the grid leak mounting is connected across the condenser. The grid leak (R₂) is clipped into the mounting. The plate (P) binding post on the socket is run to a binding post (D), which, with post C

affords the B battery posts (D and C) for the set.

The rheostat (R1) is connected to one of the filament (F) posts on the socket. The remaining filament post and rheostat post are run to set binding-posts respectively for plus and minus A battery connections (A and B).

The bulb apparatus can be connected to almost any crystal receiver in the following manner, and in accordance with the dotted lines in Fig. 1.

The minus B battery post (C) is led to that side of the crystal detector nearest to the telephone receivers ("X" in the case of The

Radio Broadcast Beginner's Set). The free terminal of the grid condenser leads to the other side of the crystal detector ("Y" on the Beginner's Set). The plus filament lead is connected to that side of the telephone receivers farther from the crystal detector, or ("Z" in the Beginner's Receiver).

CONSTRUCTION OF THE TUBE RECEIVER

IF IT is desired to add the bulb to any crystal receiver other than that described on page 366 in RADIO BROADCAST last month, the mechanics of the arrangement will be left to individual invention. The parts may be mounted into a separate unit if desired, or



FIG. 1

Complete equipment for changing any crystal receiver into a single-bulb set. The apparatus photographed here costs \$6.12. The dry cells are wired in series, forming the A battery

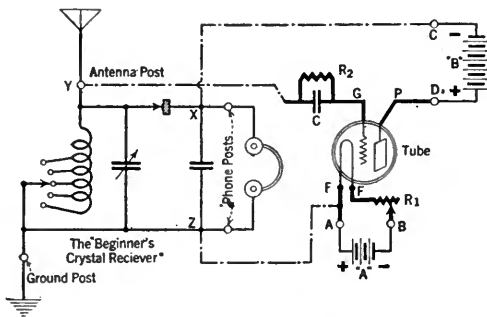

FIG. 2

The connections. The heavy line indicates the wiring of the new apparatus, and the dotted lines show how it is connected to the RADIO BROADCAST Beginner's Set

perhaps room can be found for them in the set proper as is the case with specific crystal set to which we have already referred.

The photographs, Figs. 3, and 4, clearly indicate how the single tube was combined with the crystal receiver. The combination can be effected with the same tools suggested for the original construction of the tuner.

The socket and rheostat are mounted on the top of the cigar-box cabinet and the extra binding posts two on each side. The remainder of the parts—the grid leak, its mounting, and the grid condenser—are placed inside the cabinet.

The socket and rheostat are mounted on the center line of the top of the box, with centers two and one quarter inches in from the ends. The socket is mounted with two wood screws, and the rheostat with the screws provided for that purpose. Rather than bring the wires through the "cabinet" top to the outside posts of the socket, four small holes were drilled underneath the socket prongs through which the connections were made. The wires were secured under the heads of the screws that project through the base of the socket as binding posts. The battery binding posts are mounted directly behind the antenna, ground, and phone terminals on the original set—about $\frac{5}{8}$ inch in from the rear edge. The A battery posts are behind the antenna and ground posts. These arrangements are clearly suggested in Fig. 3.

The grid condenser and grid leak mounting have the same spacing between mounting holes, so they were combined into a single unit as shown in Fig. 4. The condenser and mounting are held firmly in place by the connecting wires. A few feet of No. 18 bell wire were used in making connections.

No solder need be used in making this set an electrically efficient job.

NOTES ON OPERATION OF THE SET

THE finished receiver is a combination set. It can be operated with either crystal or bulb detector. When the crystal is adjusted and the rheostat turned off, the set will receive as well as ever on the crystal. When the tube is used, the rheostat is turned on and the catwhisker *must be lifted away from the crystal*. With this latter arrangement, the receiver functions as a single-tube *non-regenerative* set. Single-tube regenerative sets are radiators of interfering oscillations, particularly when operated by inexperienced listeners. For this reason, no slight alterations should be attempted in order to make the receiver regenerate.

The three dry cells forming the A battery are connected in series—i.e. the negative post of one cell to positive post of the next, as suggested in Fig. 1. The negative terminal is the zinc, and the positive terminal is the center or carbon. The A and B batteries are connected to their respective posts.

With new or fully charged batteries it will be necessary only to turn the rheostat "just on." As the A battery is discharged—in the course of a month or two—the rheostat must be turned farther and farther up. The operation of the set as a bulb receiver in respect to tuning is identical with that of the crystal set.

The tube should be turned off by means of the rheostat when the set is not being used.

THE RADIO PRIMER

What "Detection" Means

IT IS impossible to start at the very beginning of things. To all adult arguments and explanations, some premises must be granted. Before beginning to explain the necessity for a form of detector such as the crystal, certain conditions under which the detector operates must be admitted even when, by some, they may not be thoroughly understood.

In every receiving set, and therefore in a crystal receiver, a high frequency alternating current flows through the tuning circuits whenever a transmitting station is being received. This high frequency current is identical in every respect except in strength with that surging in the transmitter many miles

distant, and is set up in the receiver through the action of the radio wave. When the current grows more powerful in the transmitter, it grows similarly more powerful in the receiver. Every variation of the transmitting current is duplicated, at practically the same time, in all receiving sets tuned to this transmitter.

Now these variations are caused by different tones and notes impinging on the microphone in the studio of the transmitting station. With one note, the transmitting current will grow stronger, while on another it will be weakened. Thus, in the receiving set, we shall have an alternating current, the strength of which will vary with the spoken words or music picked up by the small round microphone in a broadcasting station perhaps a thousand miles away. This alternating current is conserved and brought to its maximum strength in the receiver by the process of tuning. When you twist the dials of your receiving set, you are merely adjusting local conditions so that the most can be made of the infinitesimal energy which you pick up many miles from its starting point.

MAKING ALTERNATING CURRENT "AUDIBLE"

HAVING picked up, conserved, and, perhaps, strengthened this weak alternating current, it now remains to make it audible—

to conjure it forth from the loud speaker or telephone receivers as enjoyable sound. This process is well named "detection," and it is here that the "detector" (a crystal in this case) comes into its all-important action.

A high frequency alternating current will not actuate the diaphragms of a loud speaker or telephone receivers. Both of these instruments severally consist of a permanent magnet over which are wound several thousand turns of wire. When electricity passes through these turns there exists the combination effect of a permanent magnet, such as the familiar horse-shoe magnet and an electromagnet, such as the bobbins that actuate the armature of an electric bell.

All magnets have two poles, and the lines of magnetic force are imagined as leaving one pole and entering into the other. Thus the magnetic lines of force may be said to be characterized by direction, running, as it happens, from the north pole of a magnet to

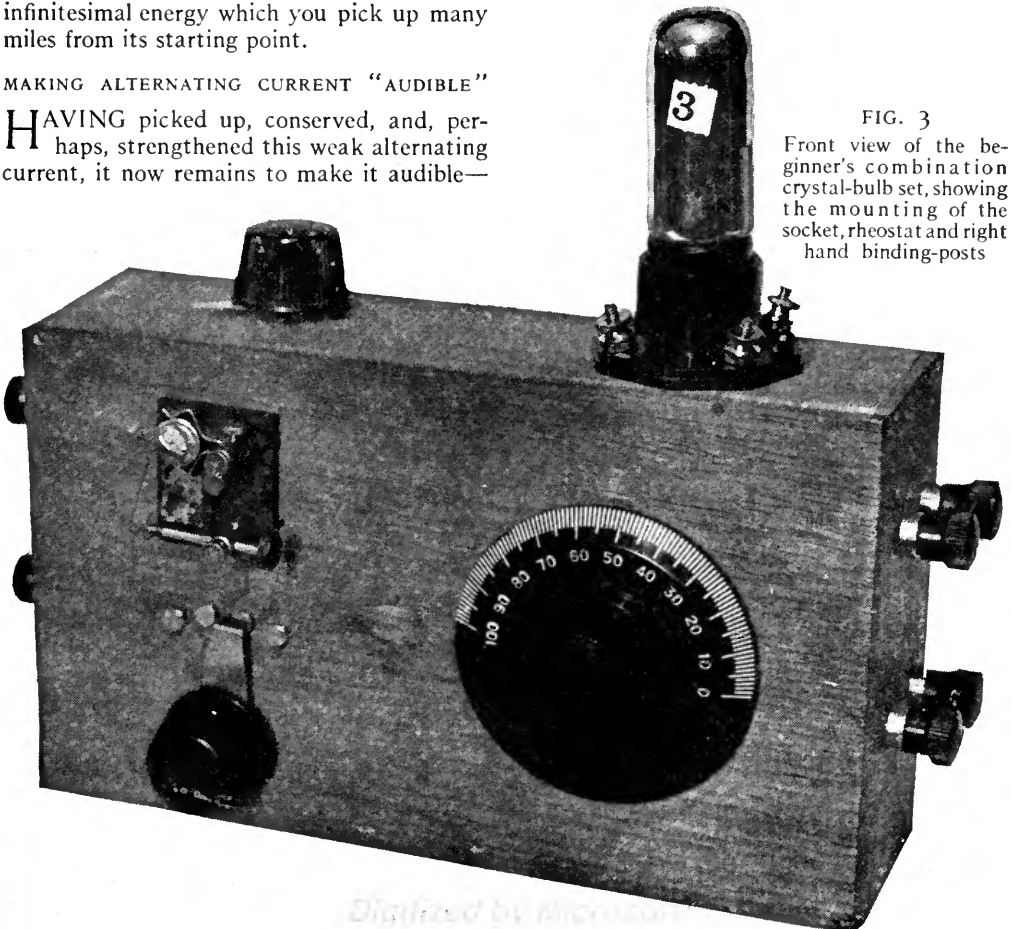

FIG. 3

Front view of the beginner's combination crystal-bulb set, showing the mounting of the socket, rheostat and right hand binding-posts

the south pole. The directions of the lines of force in an electromagnet are determined by the direction of the current flowing through the winding. When the direction of the current is reversed, the magnetic field is reversed.

An alternating current, as most of us appreciate, is a current that reverses its direction of flow many times a second. For a fraction of a second it courses through the wire or conductor in one direction. Then it weakens to zero strength, and turns about, growing stronger in the opposite direction. Its action is comparable to the motion of a piston actuating a revolving flywheel. The piston is constantly reversing its direction of motion (one reversal for every revolution of the wheel) and yet it continuously exerts a power or force that is useful. The number of times this reversal takes place is known as its frequency.

Therefore, if we pass an alternating current through the coils of an electromagnet, the direction of the lines of force, comprising the flux or magnetic field, will reverse with the alternations of the current. The action of this field is suggested in the drawings Fig. 5.

The field of a permanent magnet is, as its name suggests, permanent. It exerts a magnetic attraction without the assistance of electric current, and, excepting under very powerful electrical stresses, the polarity, or direction of the lines of force, is never reversed.

THE "WORKS" OF THE LOUD SPEAKER

WE HAVE said that the diaphragm of a loud speaker or telephone receiver is actuated by a combination of permanent and electromagnets. Let us investigate what would happen if we pass a high frequency alternating current through the winding of such a reproducer. In one direction of current flow, the electromagnetic field will assist the permanent magnetic field, and the diaphragm will be drawn farther down toward the magnet. However, with the reversal of the current (and accompanying reversal of the electromagnetic field) the electromagnetic field will oppose the permanent field. This will result in the weakening of the permanent field, and the diaphragm will spring away from the magnet even beyond the point of normal equilibrium (when there is no current flowing through the winding). Thus with every cycle or complete alternation of the current, the diaphragm will move toward and from the magnet. But in high frequency radio currents used in broadcast transmission, these alternations take place anywhere from 300,000 to 6,000,000 times per second! Due to inertia, it is im-

possible for so heavy an object as a diaphragm to reverse its motion this many times a second, and even were it possible for the metal disk to vibrate so rapidly, the frequency is far above the upper limits which the ear can detect as sound.

It is therefore necessary to rectify the high frequency alternating current, to change it into direct current, i.e., a current that flows only in one direction. Such a current will continuously oppose or assist (the more efficient arrangement) the permanent magnetic field, either releasing the diaphragm or pulling it more powerfully, respectively, as long as the current flows. It is only with a variation of the current, which it will be remembered changes with the sound impulses picked up by the microphone in the transmitting station, that the diaphragm will move, thus reproducing the sounds spoken, sung, or played in the distant studio.

Many crystals, such as galena or silicon, possess the property of unilateral conductivity, which means that they will conduct an electric current better in one direction. If an alternating current is applied to a circuit containing a properly connected crystal, the alternations in one direction will be passed quite readily, while those in a reverse direction will be weakened and impeded. This is a sort of automatic valve action, passing one half of the alternating current cycle and repulsing the other half. The final effect is that of rectification, the changing of the alternating current into a direct or uni-directional current, which is effective in actuating the telephone receivers or loud speaker.

THE RADIO LIBRARY

THE action of the crystal detector has been covered from various points of view in the following references. The student reader can obtain these books from up-to-date public libraries, and will find the indicated chapters well worth the reading.

The Outline of Radio, by John V. L. Hogan, pages 147 through 161. A very interesting and non-technical exposition on the necessity for detection and the action of the crystal rectifier.

The I. C. S. Radio Handbook, pages 174 through 180. A less elementary description of crystal and similar detecting actions.

Principles of Radio Communication, J. H. Morecroft, pages 336 through 350. A highly interesting

but mathematical exposition recommended to the student.

THE RADIO LEXICON

Important technical terms and words used in this month's department for the radio broadcast beginner:

ALTERNATION: Specifically, the reversal of an alternating electric current.

CRYSTAL DETECTOR: A detector of radio signals that functions by means of the rectifying property of some mineral such as galena or silicon.

CYCLE: The complete motion of an alternating current, from the beginning of one alternation to the end of the next.

DETECTION: The process of making audible the radio frequency currents set up in a receiving set by the passing radio wave.

DETECTOR: The instrument or group of parts arranged into a unit that performs the act of detection.

ELECTROMAGNET: A magnet about which lines of force are set up by a current

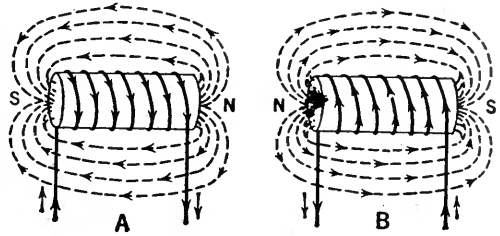

FIG. 5

Suggesting the manner in which the direction of the magnetic lines of force reverse with a reversal of current in an electro-magnet. The arrows on the solid lines indicate the direction of current flow in the wires, while the arrows on the dotted lines of force show the direction taken by the field. In A the current flows in one direction, which is reversed in B

passing through its winding. The bobbins of a door-bell are electromagnets.

FREQUENCY: Broadly, the number of times a phenomenon repeats itself within a given time. In electricity, "frequency" generally refers to the number of cycles per second of an alternating current. In sound, "frequency" means the number of air vibrations per second.

LINES OF FORCE: More or less imaginary lines of magnetic energy running from the north pole of a magnet to the south

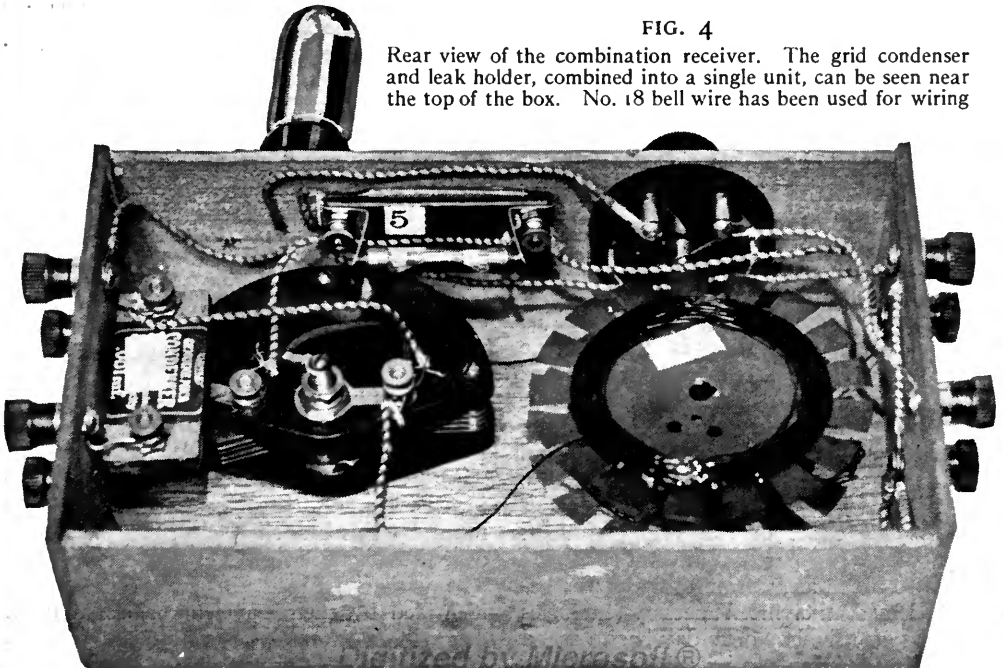

FIG. 4

Rear view of the combination receiver. The grid condenser and leak holder, combined into a single unit, can be seen near the top of the box. No. 18 bell wire has been used for wiring

pole, the sum total of which is the magnetic flux or field.

PERMANENT MAGNET: A magnet, such as the common horse-shoe magnet which is permanently magnetized through a peculiar disposition of the molecules of steel or iron. Unlike the electromagnet, no winding, passing an electric current, is required to provide the attracting field.

RECTIFICATION: The changing of an alternating current to a direct current, generally by passing one half the cycle (all motion of the alternating current in

one direction), and impeding the other half.

SELECTIVITY: The ability of a circuit or receiving set to eliminate undesired stations, while bringing in the desired signal.

SHARPNESS: The criticalness of tuning. A set that tunes sharply will tune a station in or out with a degree or two of variation on the tuning dials. Sharpness does not mean "selectivity." The use of a large variable tuning condenser will sharpen tuning without affecting selectivity.

Wavelength or Frequency— Which?

In An Effort to Clarify Radio Terminology, RADIO BROADCAST
Will Hereafter Refer to Frequencies Instead of Wavelengths

By J. H. MORECROFT

Past President, Institute of Radio Engineers

WE ARE all, being human, naturally very loath to give up one line of thought for another. It has taken a certain amount of effort to accomplish a method, and common sense tells us not to discard one habit, or scheme of thinking for another, unless a marked advantage is evident.

A most remarkable illustration of this mental inertia is our present system of units for measuring, in the so-called English system, and our hodge-podge method of spelling words.

So many times, as the writer has witnessed the efforts of school children trying to master the crazy tables of measuring units with which an elementary arithmetic is loaded, the thought has occurred to him, "How inefficient and useless is this antiquated method we have of measuring things in everyday life!" Gills, hogsheads, rods, miles, drams, ounces, and pounds, with their heterogeneous relationships, unnecessarily take up a tremendous amount of time and effort of the young student. Just because his parents haven't had the courage to break away from unit systems bequeathed by semi-civilized ancestry (apologies to Mr. Bryan) the boy of to-day has to spend many a dreary hour learning tables of quanti-

ties which had much better be replaced by others. If the metric system of units could be universally adopted in this country, the amount of time spent on arithmetic in schools might very likely be halved. But the father of the schoolboy, having an expensive set of jigs, fixtures, machines, bolts, and whatnots in his factory all worked out on the English system, does not contemplate with equanimity changing his scheme of measurement. It would temporarily seriously affect his profits. And so, through the land, millions of boys and girls continue to expend many of their precious hours memorizing useless relationships which could readily be replaced by others much simpler.

WHEN CHANGE IS DESIRABLE

EVEN a lethargic reader can see that change is many times useful and desirable. Now when radio began, the effort was made to identify electric disturbances with light, and naturally this branch of electric science took over the nomenclature of the physics of light. The various frequencies used in radio were identified by their wavelengths, as in light. So radio folk grew accustomed to speak of the wavelength of an alternating current.

The student of radio to-day finds that he has to start with the elementary laws of the alternating current circuit and in these laws he finds that the frequency of the alternations plays a very important part in the action of the current. He finds that commercial alternating currents have frequencies of 25 to 60 cycles per second, voice (or telephone) frequencies from 100 to 10,000 cycles per second. He becomes accustomed to thinking of these currents in terms of their frequencies. He learns in telephony that one frequency can be separated from another by so-called filters, the theory and action of which is explained in terms of frequencies. In carrier telephony, using frequencies perhaps as high as 50,000 cycles per second, the engineer still thinks of frequencies. Instead of speaking of 50,000 cycles he speaks of 50 kilocycles, adopting the metric system of easy conversion from one size unit to another. The electrical engineer long ago found it convenient to use the kilowatt instead of the watt, and all electric bills are now rendered for so many kilowatt hours, as every householder knows.

There is no reason at all for speaking of radio currents in wavelengths. All the theory and apparatus of the radio engineer is worked out on the idea of frequency. The Bureau of Standards early recognized the needless complexity and the uselessness of the wavelength unit and in all of its publications now uses the frequency of the radio current instead of its so-called wavelength.

THE DISADVANTAGES OF WAVELENGTH

IT SO happens that in broadcasting, the term wavelength has an added disadvantage, one which argues most strongly for change to the frequency unit. A broadcast telephone channel requires a certain width of the frequency scale to transmit the voice properly. An ordinary station rated at 500 kilocycles, for example, requires a frequency band from 490 to 510 kilocycles for perfect transmission of speech. This width of frequency band, of say 20 kilocycles, is required for radio telephony no matter what the frequency of the station's current may be. Thus a station at present rated as 150 meters wavelength requires a frequency band from 1990 kilocycles to 2010 kilocycles, a band the same in width as for the 500-kilocycle station. If we continue to think

of wavelength, however, we shall find no easy way of telling how closely two stations might be tuned without interfering with one another's channels. This separation would be 20 meters, perhaps, in one part of the radio frequency band and only 2 meters in another.

On the basis of 20-kilocycle separation, the Department of Commerce could assign frequencies every 20 kilocycles up the radio frequency scale, knowing that such assignments would not interfere. But if we stick to wavelength, we shall find the wavelength scale divided in a most irregular and apparently unreasonable manner.

Radio receiving sets can be made to have dials of uniform frequency scale. Dials and condensers of this kind are already appearing on the market.

The Department of Commerce specifies radio station assignments in both kilocycles and meters. The tendency of radio engineering practice is to use and express frequency in kilocycles rather than wavelength in meters. "Kilo" means a thousand, and "cycle" means one complete alternation. The number of kilocycles indicates the number of thousands of times that the rapidly alternating current in the antenna repeats its flow in either direction in one second. The smaller the wavelength in meters, the larger is the frequency in kilocycles. The numerical relation between the two is very simple. For approximate calculation, to obtain kilocycles, divide 300,000 by the number of meters; to obtain meters divide 300,000 by the number of kilocycles. For example, 100 meters equals approximately 3000 kilocycles, 300 m. equals 1000 kc. 1000 m. equals 300 kc., 3000 m. equals 10. kc.

For highly accurate conversion, the factor 299,820 should be used instead of 300,000.

From this number of RADIO BROADCAST, reference in the magazine will no longer be made to wavelength alone. Frequencies will be the standard, but in order not to confuse the inexperienced reader, the corresponding wavelength will always be used, in parentheses.

Page 110, of RADIO BROADCAST for November, 1924 contained instructions on how to convert wavelengths to frequencies and vice versa. The Bureau of Standards has available, for limited distribution, a conversion table, worked out on the factor 299,820. —THE EDITOR.



as the broadcaster sees it



by CARL DREHER

Drawings by Franklyn F. Stratford

Diagnosis of the Radio Amateur

WHAT is a radio amateur? Great confusion surrounds the answer, if there is one. To owners of single-circuit receivers in his immediate vicinity, the amateur is a vicious ogre who emits strange buzzing noises which interfere with their broadcast reception. To commercial operators, he is a talented young man who might even aspire to become a commercial operator. To some of the amateurs themselves, who have taken their degrees as feature writers disseminating the gospel every Saturday afternoon in the radio supplements, the amateur is the inventor of radio, from the antenna insulators to the ground, in the past; its generous and disinterested supporter in the present; and its only hope in the future. To several score of other witnesses he is several score of other things.

The dictionary, with its definition of an amateur as "one who is attached to or cultivates a particular pursuit, study, or science from taste, without pursuing it professionally," helps us but little. I venture to assert that from one third to one half of all the "amateur" radio men in the United States are making, or trying to make, money in the radio field, although not directly out of their activities as amateurs. That is, they make no money out of their radio telegraph activities,

but they keep radio shops or service receiving sets or run broadcasting stations for pay. Yet they remain amateurs in excellent standing. Now we are beginning to see light. An amateur, in radio, is a person who experiments gratuitously with transmitting sets—generally radio telegraph transmitters—and with receivers adapted for communication with transmitting sets so tended; but who is free, without prejudice to his amateur standing, to make all the money he can out of radio otherwise. If he telegraphs around the country with just one set, and receives ditto, purely for the love of it, then his standing as a radio amateur is secure, and he can collect all the cash he is able to get in any other radio activities whatsoever. It is a unique conception, and as far as I know, peculiar to radio. The jealous differentiation between amateur and professional which prevails in athletics, for example, is entirely absent in radio. The boys out in the wheat belt, nursing along their five-watters because they can't afford replacements until they save up some more pocket money, and Mr. E. H. Armstrong, who has realized an amount said to run into six figures in royalties from his radio inventions, both claim the title of amateur, and are equally proud of it.

The fact is that one must look on amateur

radio as a species of freemasonry. The spirit of fellowship and brotherly sympathy is certainly there. If you don't believe it, attack the amateurs singly, or *en masse*, and see what happens to you. They are a scrappy lot, and if they ever fall, they will fall together. They have other lodge characteristics. They delight in titles, such as "Traffic Manager, Delta Division." These titles, while undoubtedly they mean something, and frequently involve a lot of work in the way of staying up until 4 A. M. relaying messages and preparing reports, do not carry quite as much weight or responsibility as the corresponding position in a quarter billion-dollar corporation. These dignitaries are somewhat on the order of the Grand Omnipotent Ruler of a lodge; he may be grand and all, but he isn't really omnipotent. And they write numbers and letters after their names, such as "Marcus Gavotte, 12 GHQ," which astound and flabbergast the laity, who imagine that these mystic designations are so many Ph. D.'s and Orders of the Bath, if not Congressional Medals of Honor. (As I write these sentences I can visualize innumerable Division Managers glowering at me across the country and sitting down at their "mills" to write me fiery letters. Peace, gentlemen! Before I get through you will hear such praise of your fraternity that your only impulse will be to catch the first train to Garden City for the purpose of decorating and embracing me.)

The telegraph code itself, while invented purely for the purpose of communication by symbols, and so used commercially, becomes, in the hands of the amateurs, a medium with something ritualistic about it, fulfilling a function not unlike that of ceremonies and liturgies in secret orders. Is the comparison far-fetched? If so, why do the amateurs use their lingo orally and in writing, at every opportunity? It is impossible for one saturated amateur to write to another in English; they get to a point where they must express everything in pigeon-Phillips (code) and Continental abbreviations. I should not be surprised to hear of one amateur walking into the

office of another and asking him for a job in these words: "Sa OM QRW? I am QRXing for a job. QRU? Nil? Sorri tks 73s c u agn gb gb dit dit dit dah dit dahhh". This lingo is not used merely for brevity and convenience; it is also a philological toy, possession of which sets one off from the common herd. I am not immune myself. I have in my office a key-and-buzzer telegraph which communicates with other departments of the station, and, while its use is largely limited to acting as a calling device for a telephone line, I have noticed that it excites the admiration of lay visitors. No matter how busy I am, I am rarely able to resist the temptation to exchange reminiscences with an old operator, to dwell sentimentally on the never-to-be-forgotten note of HA, and to brag about the time when I could copy 35 a minute in 10-letter code.

But, aside from these factors, undeniably there is a certain magic in dots and dashes. There is a rhythm and lilt to the sending of a good operator which is capable of producing a definite esthetic response in a trained listener. It is even possible to put across rudimentary emotional states by variations and shading in the style of transmission. Even a novice can tell when the man at the other end of the circuit is impatient or angry or confused. Styles of sending are as numerous as the shapes of men's ears, and as varied as their ways of walking and talking. Many amateurs, as well as professionals, are connoisseurs of the subtleties of code work. Many others—probably the majority—are and will always remain rotten operators, just as the majority

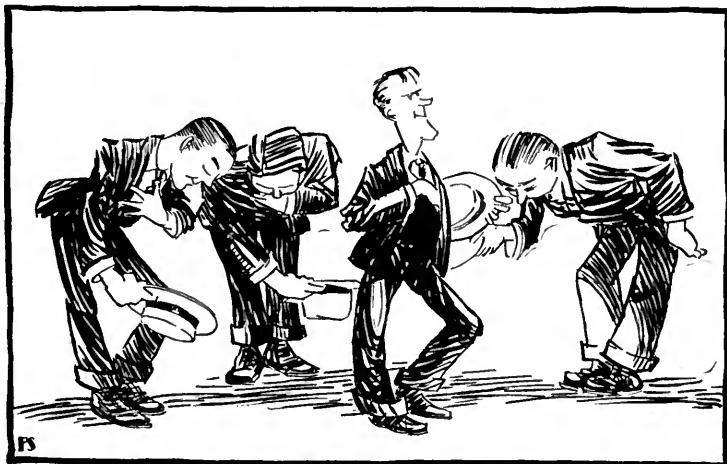

let us dust the earth to the amateur

of people who learn to play the piano simply learn to murder the instrument and the music. There are always more dubs than artists. That there are artists among amateur radio telegraphers, no one who has any feeling for these matters will attempt to deny.

Neither would I deny that the traffic men of the American Radio Relay League sometimes try just as hard to get a message through as any commercial operator. But not one out of 500 such messages means anything. When anybody has a message he wants delivered, he gives it to a commercial telegraph company. The difference between the work of the amateurs and that of commercial interests is the difference between a sham battle and a real one.

A great deal has been written about the ingenuity of amateurs and experimenters in building their own sets, transmitting and receiving. It is true that some of them show immense skill, but things should be called by their proper names, and it is a fact that no amateur, experimenter, or other isolated individual is in a position to build even a simple radio set. He can only assemble one out of factory-built parts. What amateur or radio fan makes his own audio transformers, vacuum tubes, telephone receivers, plugs and jacks, bakelite panels? It is purely an assembly and wiring proposition. The creativeness of the amateur, therefore, is at best a secondary one.

Liberal mixed with hokum, also, are the vast and all-embracing claims made for the inventive genius of the amateur. To read some of these narratives, one would think that radio had sprung full grown out of the foreheads of a lot of sixteen-year-old geniuses. What first-rate radio invention has been made by an amateur? The work of Armstrong will immediately be cited. But at the time that Armstrong was doing his early work on regenerative circuits he was a student at Columbia University and had the run of the unexcelled Marcellus Hartley electrical laboratory on Morningside Heights. He did not yet have the degree, but he was already a distinguished electrical engineer in every other respect. However, instead of laboring the point, let us classify Major Armstrong's early work as an amateur achievement. What then? One swallow does not make a summer. What other first-rate radio inventions have come out of amateur circles? How many second and third-rate innovations, even? I know of few, very few. The unromantic fact is that most of the inventions that have brought the

art to its present level have come out of well-equipped physical laboratories, after developing from the ideas of trained investigators and engineers. A great number have originated in the research departments of great industrial corporations, thence percolating down to the amateurs. The business of invention and research has become highly intricate, and is no longer carried on to the best advantage in a garret.

So much for the negative. Now let us give credit where credit is due. Given the inceptive ideas, the amateurs have again and again, with immense industry and ingenuity, developed fields of radio scarcely touched by other interests. The present short-wave fever is an instance. The value and specific utility of the very high frequencies is still only partly determined, but at any rate research in this field will yield interesting and important data. Men like Reinartz and Schnell are among the leaders in this experimenting. If they do not initiate the great theoretical and practical advances, the amateurs do undoubtedly mop up brilliantly in the immediate wake of the pioneers. Let an idea be published, and immediately a few thousand of them are at work squeezing the juice out of it, trying out all the variations, and showing that it can be made out of tin cans and empty tooth paste tubes.

Secondly, amateur experience is an excellent preparation for commercial activity in the radio field. Look up copies of the radio magazines of 1910 to 1914, and you will discover the names of many prominent engineers, commercial men, and operators of to-day signed to amateur articles. In another decade many of the younger amateurs of to-day will be running the works.

In time of emergency, this process is considerably expedited. During the last war, the signal services of both the army and the navy drew a sizable proportion of their personnel from the ranks of the amateurs. Some of these men required no training. Others needed only a fraction of the training which would otherwise have been necessary. The time thus gained was precious. Similar emergency service may be rendered by the amateurs in time of earthquakes, floods, or other disasters. A country with fifteen or twenty thousand more or less skilled telegraphers and radio signal men available as reserves behind the professional operating staffs, is that much better off when communications get into a jam.

Thirdly, the amateurs are amusing them-

selves, instead of paying someone to amuse them. They are playing ball, instead of watching someone else do it for \$20,000 a year. Even if their activities were purely recreational, they could be amply justified. It is a good thing to get one's fun through one's exertions, rather than to have it served up, cooked and predigested, on a platter. Let us dust the earth with our hats in salutation to these young men who reach out six thousand miles, across seas and continents, for their amusement.

Why Summer Broadcasting is Better

ANOTHER reason for cleaving to radio throughout the summer, the argument in this case being addressed to symphony concert listeners:

A large orchestra sounds better, by direct audition, indoors than outdoors. The brilliancy of the strings is superior, and much detail is perfectly clear indoors, where it is partially lost outdoors except to those members of the audience who have seats well up front. (This is for the connoisseurs and great musical sharks; probably most listeners would not make the distinction.) But, by radio, a big outdoor orchestra is usually better than the same orchestra in an auditorium, owing to the relative absence of reverberation. Hence, for the best symphonic radio music, listen during the summer. You will get good stuff all year around, but the summer has, as the sporting writers say, the edge.

Daylight Broadcast Reception

MR. ALEXANDER L. SHERIDAN of South Raub, Indiana considers the night-day ratio of signal strength, quoted on page 76 of the May issue, as too high. This figure, it will be remembered, was quoted from the well-known paper of Nichols and Espenschied, wherein it appeared that the power of a broadcasting station would have to be multiplied by a figure of the order of 10,000, in order for it to supply the same signal at a distant point during daylight as the signal received at that point *during the best times at night*. With a standard superheterodyne receiver, using external loop and outside antenna combinations, Mr. Raub is able to hear WGY, WCAE, and KDKA, day and night. At the time he wrote (April), WEA, 800 miles away, was audible, although not quite understandable, at noon. During the preceding December, and January, states Mr.

Raub, he was able to hear WEA on a loud speaker any time after 2.30 P.M. S. C. T., and to determine the nature of the material broadcast. WEA's power at this time was 1.5 or 2.0 kw. Accordingly, our correspondent does not believe that the discrepancy between day and night reception is as high as reported.

These observations are very interesting, and, certainly, data on daylight reception is most welcome, being rather scarce in the broadcast field. However, there is little in the above data to discredit the observations of Messrs. Nichols and Espenschied, and any one who knows these engineers and their methods of procedure would hesitate a long time before challenging any of their results. In our quotation we were careful to retain the qualifying clause relative to "the best times at night," those periods, that is, when the signal rises to a peak value based on an inversely-as-the-first-power-of-the-distance attenuation. Normally the received signal drops off according to a higher power, owing to the absorption it encounters along the way. Sometimes, at night, through the fortuitous and uncontrollable action of meteorological forces in the great open spaces, this absorption is wiped out for a few seconds. These are the crowded moments for which the DX hunter prays; their occurrence is his glory, their brief duration and rareness make him miserable. All that Messrs. Nichols and Espenschied said was that to duplicate that transitory night peak with a continually serviceable daylight signal of the same strength, over the same distance, you would need 10,000 times as much power. I believe you would. All that Mr. Raub has shown is that, given the

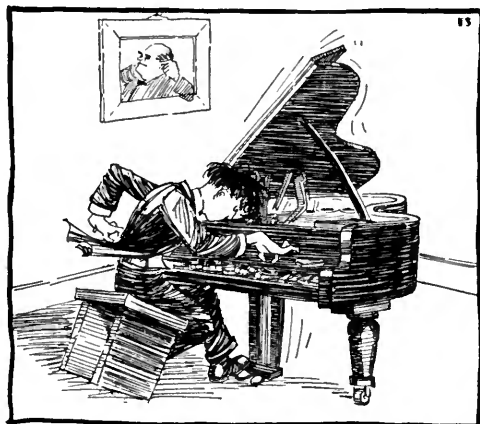

they learn to murder the instrument

almost incredible sensitivity of the modern super-heterodyne, one can hear the higher-powered broadcasters over very considerable ranges in daylight, a fact which no one will dispute.

It should be noted that in this discussion the important distinction between hearing a signal well enough to log it, and getting it well enough to justify use of the term "program service," has not yet been introduced. At the risk of wearying our readers, we once more point out the necessity of clearly understanding what we are talking about in this respect. The interest of this department, and our whole manner of thinking about radio problems, generally centers about program service rather than catching on the fly some distorted sounds which are here now and gone the next minute. This is not to say that one cannot have a lot of fun with DX signals; a few million people are ready to testify that one can. But the serious development of radio is clearly in the direction of immaculate program service for an ever increasing number of people. By such service we mean a signal of about phonograph volume, at least as good as the best phonograph quality, and free from annoying disturbances, natural and artificial. Hence the trend toward higher powers. Hence the usefulness of quantitative data covering both day and night conditions in broadcast reception.

The Memoirs of a Radio Engineer, III

(Continued from the July Number)

OCCASIONALLY rumors came our way of the wonders and potentialities of "wireless." A seventeen-year-old cousin of a friend of a member of the gang was said to be telegraphing across his backyard in Yonkers, without the use of wires between the two stations, although there was plenty of wire at either end. Another enthusiast had erected an antenna on his roof and was engaged in what he called transmission, using a spark coil, until his mother happened to come in contact with that antenna while she was engaged in hanging out the wash. His experiments were abruptly terminated, and the subsequent spanking was said to have been of volcanic violence. Another inventor, according to reports, was engaged in destroying nickels, and even a dime, with a file, in an endeavor to construct a "coherer." We did not know what the coherer was supposed to do, but we were agreed that the only explanation of the experi-

menter's conduct was madness. Would any sane boy attack a dime with a file?

Nevertheless, we were not sure. Possibly the fellow expected to realize some special raptures through his sacrifice. Wireless began to appeal to our imaginations. Thereupon, of course, we were lost. We had to have a "wireless."

We secured a piece of glass tubing, two nails, and a nickel. Securing some filings from the coin, we placed them between the two nails, and, according to the books, we had a coherer. An electric bell, wired for single stroke operation, was the decoherer. But we had no relay, and there was not the slightest chance of acquiring one. Furthermore, there was no transmitter, and therefore nothing to receive. Finally, while it was possible to get clear and detailed information from the boy electrician books about batteries, sounders, motors, and the like, the data on wireless was fragmentary, and we suspected that the authors knew little more about it than we did. After a period of despair, we were saved by a description of an "auto-coherer," consisting of a carbon and a steel rod in contact with a drop of mercury within a glass tube. It was said to have been invented by Marconi, and to be in use in the Italian Navy. The virtue of this instrument was that it was sensitive and would operate a telephone receiver. We had two seventy-five-ohm receivers of the "watchcase" type; one of the boys had got them as a Christmas present, and we had constructed a primitive telephone line with them in the intervals of our telegraphing. The materials for the auto-coherer were obtainable. The nail and glass tube we had. With a hacksaw blade we cut a carbon rod out of an old dry battery carbon, and filed it down to approximate roundness. The physics teacher in the elementary school gave us a few drops of mercury. To our delight and astonishment, the detector worked. The telephone receiver being connected to it, the discharge of a Leyden jar in the next room could be heard as a distinct click. One could send dots with it, but no dashes. We arranged a set of signals on this basis. In order to send even one dot, of course, it was necessary to charge the Leyden jar with the electrophorus, which took several minutes. It was not high speed telegraphy, but it was "wireless," undeniably.

We now heard of a still simpler and even more sensitive form of detector of the microphonic type. This consisted of two steel needles, stuck into a piece of wood and pro-

vided with leads, and a piece of pencil lead laid across them. It worked with a telephone and a local battery. It was said that, placed on a cigar box, it would register the noise made by a fly walking across the box. We placed it in this position and waited patiently for a fly to promenade thereon. But the flies were wary. It was necessary for us to catch a beetle, and, indeed, he was quite audible in the telephone receivers as he scampered off the box. But this was not wireless, we realized. It was a digression.

At this time (early in 1909), there were already wireless amateurs who had reached a stage much in advance of ours. In the same year they founded the "Junior Wireless Club, Ltd.," with headquarters at the Hotel Ansonia, where the President, W. E. D. Stokes, Jr., had his home and antenna. The history of this group was graphically described by my friend George Burghard, now President of the Radio Club of America, in "Eighteen Years of Amateur Radio," (RADIO BROADCAST, August, 1923). These were the genuine amateur radio pioneers in the East. Some of these boys had started experimenting as early as 1905. They were about four years ahead of us, and some five years behind the commercial radio pioneers of this country. Our group in upper New York might therefore be classified as part of the third pioneering migration with some of the ground already cleared and the Indians no longer on the offensive. But we were on our own. We had no contacts with the West Side aristocracy of radio amateurs, whose resources and facilities were far superior to ours, enabling them to establish two-way communication over distances up to a mile at about this period.

However, we heard of an amateur about a third of a mile from our location, who had a transmitting set consisting of an antenna, a spark coil, spark gap, key, and battery. He was languishing for someone to listen to him. If we would put up an antenna, he would send to us. This appealed to us irresistibly. We secured two poles, one about fifteen feet long, which we placed on the roof of the two story frame house in which I lived, and a somewhat longer one which we were allowed to erect on the roof of a barn some sixty feet distant. Between these poles we swung a 4-wire antenna of the flat-top type, not much different from those now in use. The wire was No. 18 annunciator; broomsticks served as spreaders, and the insulators were porcelain cleats. The lead-in ran into my mother's kitchen, and we obtained a ground on the water faucet. One

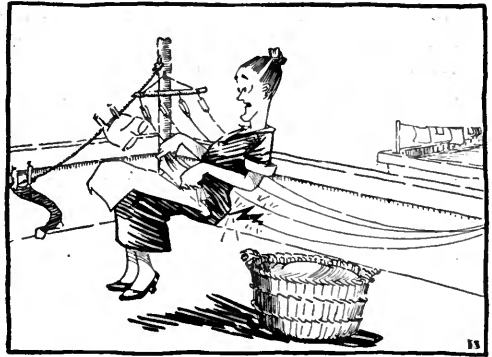

"...in sudden contact with the antenna"

afternoon in June the great experiment came to a climax. Our steel needle-pencil carbon detector was connected to the antenna and ground, in parallel with the battery and telephone. The latter was pressed to the ear with the hand; we had no headband. Tuning there was none. The combination was probably aperiodic, or nearly so, and would respond to a wide band of frequencies, given a signal strong enough. It worked as soon as it was put together. We had arranged to use the call "YF," and the first fellow to put the telephone to his ear heard the tripping Morse accents of the transmitting operator up on Prospect Avenue. A look of ineffable joy overspread the face of Lamont Whitney, who was the first, I believe, to listen at our end, and we knew he was hearing something. (He is now chief operator on the SS. *President Roosevelt*, and no doubt it takes more than a radio signal to make him happy now.) With reluctance he yielded the telephone receiver to me, and I heard the low-pitched, perfectly clear buzzing of the spark coil six blocks away. We took turns at listening all afternoon. In all, I believe, there were four of us. We also listened in the evening, but heard nothing. We left the apparatus connected and went to bed, I in my room not far from the lead-in, and the other boys to their homes.

The experience of the afternoon, and the proximity of the wireless receiver, excited me so that for some hours I did not sleep. Finally I drifted off. At about two o'clock in the morning I awoke with a sense of impending disaster. Something had frightened me. I sat up in bed, my heart thumping. It was a hot, sultry night. Suddenly I knew what it was. An ominous distant growling, followed by a crash, broke the stillness of the night. A lightning storm was approaching. I had a

vague notion that radio had something to do with lightning, and that it was the proper practice to ground the antenna when not in use. This we had neglected to do. Actually, of course, the risk was infinitesimal. The antenna might have been left ungrounded all through the thunderstorm, and nothing would have happened. I was not taking nearly as much risk as I did daily hitching on the back of ice-wagons, climbing trees, and fighting. But how was I to know this? I visualized the antenna on its long poles sticking up provocatively above the roof of the house, and all the time the storm was coming nearer, the lightning lit up the room with ghastly blue flashes, and the thunder began to shake the windows. It seemed to me that inevitably the lightning must hit that antenna and the house, with my father, mother, and sister, would all be incinerated. My teeth chattered; I was sick with fright. The thing to do, I realized, was to get up and ground the antenna before the storm came any nearer, but I was afraid to go near the lead-in. I was a boy of thirteen, in conflict with stupendous cosmic forces. I began to whimper. My parents, sleeping in the next room, had also been awakened by the storm, and they soon heard me. My father appeared in his nightshirt and demanded the cause of my tears. I informed him, sobbing, that the house was about to be struck by lightning. He immediately understood that there was some connection between the antenna and my fear of lightning a thing which had not occurred to him before, or probably he would not have permitted the

erection of the antenna. The gas was lit; the whole family was aroused, and stood about quaking; my father was angry and denounced me as a young fool in tones which rivaled the thunder. This aroused my resolution. I leaped suddenly out of bed and charged across the hall to do or die. I grasped the antenna wire frantically—and nothing happened. I was not electrocuted, not even a spark leaped to my hand. Tearing the wire from its connection to the detector, I wrapped it around the water pipe, just before my father collared me and dragged me away from the set. The storm passed over and faded into the distance: with it, the alarm subsided, and my family went back to bed. My father lectured me at length the next day, but he allowed the antenna to remain up, having received assurances from other sources that it was not dangerous. But I was compelled to swing the lead-in from the kitchen down to a small storage house in the yard. And there, for reasons to appear, we had no further success in our wireless experiments.

I have recounted this hysterical scene, not only for the amusement of my readers, but to show what a part unreasoning fear plays in the psychology of people whenever they are faced by anything unknown. Since those days, millions of antennas have been erected and used without damage from lightning. They are no more dangerous than telephone or electric light service wires. For half a dollar one gets a lightning arrestor which supplies all the protection needed. But things were different in 1909. (*To be continued*).



I tore the wire off the detector

The Power of Broadcasting Stations

A NEW broadcasting station announces: "While rated at 1000 watts, the actual power attained when voice or music are in the air will reach a peak of 2500 watts." And so the press releases speak of the purchase of "a new 2500-watt . . . transmitter."

On that basis it would be just as reasonable to rate the set at 250 watts. For, each time that a 2500 watt peak is reached for $\frac{1}{1000}$ second or thereabouts, in the next $\frac{1}{1000}$ second the power will drop to about zero. The method of operation of the Heising system of modulation is that the modulating power is alter-

nately added to and subtracted from the carrier power. Thus the average or effective radiating power is that of the unmodulated carrier, and the carrier power is the proper rating of the station.

A corollary question which arises is: How much should the carrier be modulated? My own answer would be: 80 per cent. on the highest peaks. No higher, for if this figure is exceeded over-modulation will inevitably result at times. With a 20 per cent. margin, one can reduce accidental over-modulation so that it is very rare. Nor should the percentage of modulation be much below a maximum of 80 per cent., for two reasons. First, the loss in signal strength; secondly, the fact that in the receiving set the carrier amplifies any disturbances that may happen to be floating around, more or less in proportion to its amplitude, regardless of the modulation. If, therefore, a station has a strong carrier field at any point, weakly modulated, it is amplifying disturbances to the disadvantage of its own signal. The 80 per cent. figure steers a course between the devil and the deep sea.



I took the child from the "mike"

Presidents with George Washington and Abraham Lincoln.

THE EPIC OF THE LITTLE CHILD

HASTILY written report of a field operator at wjz in explanation of noise interference at the beginning of a hotel music program:

At the beginning of the first number a little child got to rattling the mic. stand and pulling the mic. cord and I not being able to see it I didn't know what the matter was but was put on the air again and I discovered the trouble and cleared the trouble by taking the child away from the mic.

Brutal field operator! We hope the child's mother broke a soup tureen over the operator's head.

Who Will Lay It? A gentleman wrote to a broadcasting station inquiring whether any one had thought of using a submarine cable to bring broadcast material from Europe to the United States, thence to be re-broadcast from American stations. Some harassed member of the technical staff answered that the idea was not feasible, for the electrical characteristics of existing types of long cables were such that they would not transmit the rapid variations of speech and music. Rebuttal was as follows:

You say the Atlantic cable cannot be used to transmit. Well, let us lay a Radio Cable some concern with money or the Government.

Who are we to say that it can't be done? Maybe it can. We will need \$2,500,000 for research. Another \$5,000,000 will cover the manufacture and laying of the new marvel of science. Total, \$7,500,000. Will some philanthropist with that much money incommode him please remit as soon as convenient?

Microphone Miscellany

THE MIRACULOUS MR. BURROWS

ITEM from the New York *Times* of May 8th:

Geneva, May 7 (A. P.)—Broadcasting by private European companies will be regulated from Geneva, with the arrival here to-day of Arthur Burrows, an Englishman, who has been appointed mediator for all broadcasting companies.

His special mission is to prevent the clashing of wavelengths and consequent interference of aerial concerts with each other. Geneva was chosen for the base of operations because of its steady growth as an international centre and its central geographical position.

Burrows expects to produce order out of the chaos that has disturbed European listeners-in.

This is delightful indeed. Here we are breaking our heads over this situation, and a solution is ready at hand. If Mr. Burrows can perform as predicted, we propose that he be invited to the United States and, the constitutional inhibition on a foreign-born president being waived, he may be voted to that office by acclamation. He can then proceed to iron out the new stations-no wavelengths problem which has our Department of Commerce so worried, and he will rank among



An Induction Loud Speaker



The Acoustical and Electrical Characteristics of a Loud Speaker Capable of Handling Large Amounts of Energy and which Produces Sounds of Tremendous Volume with Negligible Distortion—The Mathematics of Its Design

By C. W. HEWLETT

Research Laboratory, General Electric Company

THE loud speaker described in this paper cannot be used for the purposes of the ordinary broadcast listener, but it is an electrical device of extraordinary interest. Because it can handle such large quantities of power and reproduce voice and music with such unusual faithfulness, this device has attracted a great deal of attention. This paper was delivered before a recent meeting of the Radio Club of America, in New York City and is full of the theory and mathematics of design, but it is an interesting and complete presentation of an excellent piece of work.—THE EDITOR

THE problem of reproducing speech and music by electrical means may be arbitrarily divided into four main parts. The first of these concerns the operation, known technically as "pick up." In this operation, the sounds to be reproduced are allowed to produce electrical effects which are usually quite small. The second part of the problem concerns the amplification of the small electrical effects produced by the original sound waves. The third part of the problem concerns the transmission of the electrical signals from one place to another. This usually occurs between the stages of amplification. The fourth part of the problem is that of reproducing sound waves by means of the amplified electrical effects. In case the transmission is accomplished by electrical waves in space, there is still another part of the problem, namely, that of receiving the signals. This may, however, be included in the division of the problem concerning amplification, because many of the considerations involved in radio reception are of a similar nature to those involved in amplification.

This discussion will concern itself mainly with the fourth part of the problem as outlined above; namely the reproduction of speech and music by operating by electrical means upon a particular type of "loud speaker."

The loud speaker, which I shall describe and discuss, is known as the "Induction Loud Speaker," and has already been described in its essential features in previous publications (*Phys. Rev.* 17, p. 257, 1921 and 19, p. 52, 1922. *Jr. Opt. Soc. Am.* 4, p. 1059, 1922). For the sake of completeness I shall repeat here a brief description of the construction and principle of operation of the instrument.

ESSENTIALS OF THE SPEAKER

THE induction loud speaker consists of two flat circular coils mounted coaxially on either side of a circular sheet of metal such as aluminum. Fig. 1

shows a picture of the parts, and Fig. 2 several models of the assembled instrument. Each coil is made up of sections with annular air spaces between them. These sections are secured to the wooden framework by means of wires which pass around them and through holes in the spider. The sections are connected in series and the terminals of each coil are brought out to two binding posts fixed to the circular frame. The circular diaphragm of aluminum has the same diameter as that of the circular framework. It is lightly held between the two frames by small pieces of felt placed between the diaphragm and each frame at intervals of about 3 inches around its circumference. This method of support leaves the diaphragm quite free to vibrate through such amplitudes as are required of it and allows it to expand when it gets hot. It also allows a certain amount of convection of air to pass upward between the coils and diaphragm and out at the top between the frames and diaphragm. The two coils shown in Fig. 1 are 25 inches in diameter, have an axial width of about $\frac{1}{2}$ inch and contain about 75 pounds of 45 mil wire. The frames and diaphragm are 30 inches in diameter. When mounted the coils are about $\frac{1}{4}$ inch from the aluminum diaphragm, whose thickness is 10 mils.

In operation the instrument is connected as shown in Fig. 3.

The generator sends a direct current through the coils which are connected so that the two magnetic fields due to this current oppose one another. The resultant magnetic field in the space occupied by the diaphragm lies along the radii of the diaphragm. The by-pass condensers C C enable the voice current from the amplifier to pass through the two coils in multiple. From the standpoint of the voice currents, the instrument is an alternating current transformer, the two coils being the primary and the aluminum diaphragm a one-turn secondary. The alternating current in the diaphragm distributes

itself throughout the whole diaphragm, and the flow lines are circles concentric with the axis of the diaphragm, and consequently are at right angles to the radius of the diaphragm at all points. The magnetic field, due to the direct current, and the induced voice currents in the diaphragm, are therefore at right angles at all points, and the diaphragm experiences an electrodynamic force of the same character as the wave form of the voice current. This force is distributed fairly uniformly over the whole of the diaphragm, and to a high degree of approximation, the phase of the force is the same at all points, at least for the range of frequencies concerned in the reproduction of speech and music.

CHARACTERISTICS OF THE SPEAKER

THIS instrument reproduces speech and music with remarkable faithfulness, but its sensitiveness is much below that of the more usual types of sound reproducing devices. On account of its size and ruggedness, however, it may be supplied with large amounts of power, so that an enormous volume of sound may be produced. In fact, the device readily lends itself to the field of public address where thousands of people are to be reached in large auditoriums, or even out of doors.

This instrument embodies several features which

are obviously of great importance for the faithful reproduction of speech and music. In the first place, the diaphragm is aperiodic which, while contributing to the instrument's lack of sensitiveness, eliminates all distortion due to resonance. In the second place, the force moving the diaphragm is distributed fairly uniformly over its whole surface so that the diaphragm moves as a whole, there being no tendency for it to vibrate in segments, which might result in resonance at frequencies corresponding to its partial vibrations. Thirdly, the large area of the diaphragm results in relatively efficient radiation over the lower range of frequencies, without the use of a horn. In speech and many forms of music most of the sound energy is carried by the lower frequency components, while the naturalness of speech is lost if these lower frequencies are not present in sufficient quantity. In the fourth place, the instrument is simple and rugged in construction and does not require any fine adjustments. When once put into operating condition it will remain so indefinitely.

OPERATION OF A LARGE DIAPHRAGM

IN ORDER to make some calculations of what we should expect in the performance of a large area diaphragm, we shall make certain simplifying

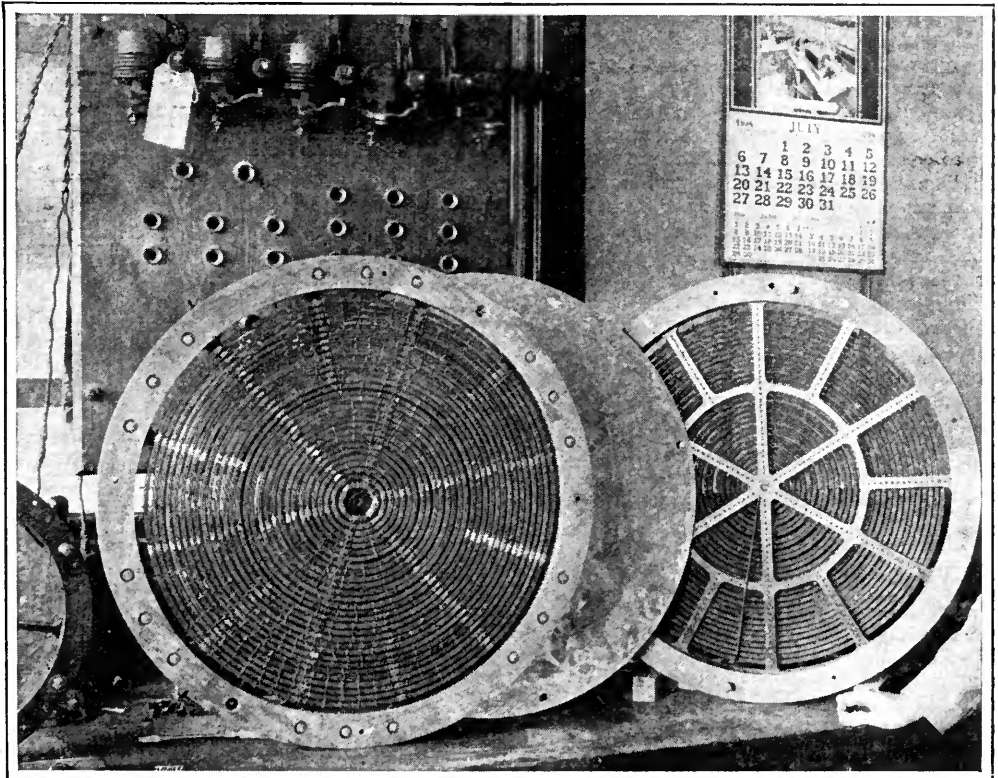

FIG. 1

Several of the Hewlitt Induction loud speakers in a corner of the research laboratory of the General Electric Company at Schenectady

assumptions in regard to the boundary conditions in the surrounding medium, and in regard to the driving forces acting on the diaphragm.

In the first place, we shall assume that the diaphragm moves as a whole when vibrating. The degree to which this is realized in practice depends upon the distribution and phases of the electrodynamic forces over the diaphragm; upon the natural periods of vibration in which the diaphragm may vibrate owing to its elastic properties; and upon the manner in which it is supported. The polarizing field, which is radial, is weak near the center, but fairly uniform over the major portion of the diaphragm. The magnitude of this component of the field in gauss is very roughly given by the total ampere-turns on both sides of the diaphragm divided by the diameter of the diaphragm. The induced current in the diaphragm should be most densely distributed in the central portion of the diaphragm where the radial field is the weakest. Since the electrodynamic force acting on the diaphragm is proportional to the product of the radial field and the current induced in the diaphragm, it would seem that to a first degree of approximation we would be justified in assuming that the force is uniformly distributed over the diaphragm. This assumption neglects whatever phase difference exist between the induced currents in the different parts of the diaphragm.

In regard to resonant periods the diaphragm is so large, and so loosely held between the edges of the supporting framework, that the fundamental period would be only a few cycles per second. Moreover the restoring force is so small, and the dissipation so great on account of the looseness with which the diaphragm is held, that the partial vibrations would not arise with appreciable intensity. The fact that the diaphragm is held around the edges should not affect its motion very far from the edge, for the maximum amplitudes of motion under ordinary conditions of use would not exceed 1 mm. for frequencies as low as 30 cycles, and for higher frequencies, the amplitude falls off almost as fast as the inverse square of the frequency. Actual listening tests have shown that the quality of speech or music produced by a large diaphragm, say 2 feet in diameter, suspended by two strings cannot be distinguished from that produced by one clamped around the edges.

INTENSITY OF SOUND WAVES FROM A LARGE DIAPHRAGM

WE SHALL also assume that the diaphragm is bounded by an infinite plane which is at rest, and that the medium extends indefinitely in all directions on both sides of the plane. In actual practice, the instrument is not bounded by a large plane. This assumption introduces very little error into the calculations we shall make for waves short compared to the circumference of the diaphragm, but when the length of the waves becomes comparable to the circumference of the diaphragm, the calculation will give too great radiation, and the error will be greater, the longer the waves.

The problem of calculating the intensity of the

sound waves given off from a vibrating diaphragm under the conditions as we have limited them has been solved by Lord Rayleigh. (*Theory of Sound*, Vol. II, p. 162-169).

The equation of motion for a simple harmonic application of force is

$$m \frac{d^2x}{dt^2} + k \frac{dx}{dt} + n^2x = F \cos \omega t$$

where x is the displacement of the diaphragm from its position of equilibrium, F is the maximum value of the harmonic force impressed on the diaphragm, $\omega = 2\pi$ times the frequency, n^2 is the elastic force opposing displacement for unit displacement,

$$m = m_0 + \frac{\pi \rho}{2 \alpha^3} K, (2 \alpha R)$$

Where $K_1(z) = \frac{z}{\pi} \left(\frac{z^3}{1^2 \cdot 3} - \frac{z^5}{1^2 \cdot 3^2 \cdot 5} + \frac{z^7}{1^2 \cdot 3^2 \cdot 5^2 \cdot 7} - \text{etc.} \right)$

and m_0 is the mass of the diaphragm, ρ is the density of the air, $\alpha = \frac{2\pi}{\lambda}$ is the wave length of the air vibration set up by the diaphragm, R is the radius of the diaphragm.

$$k = \nu \rho \pi R^2 \left(1 - \frac{J_1(2 \alpha R)}{\alpha R} \right)$$

$J_1(z)$ is the Bessell function of the 1st order of z , and ν is the velocity of sound.

In the case under discussion, the diaphragm vibrates across a radial magnetic field, so that there is a magnetic damping force acting on the diaphragm in addition to that due to the emission of sound waves. The approximate calculation of this effect is given in appendix I and is shown to consist of two force terms, one multiplying the displacement, and the other the velocity. Both terms are shown to be negligible compared to the other terms present.

The force driving the diaphragm arises from the interaction of the radial magnetic field and the currents induced in the diaphragm by those in the coils. In appendix II, the approximate magnitude of this force is calculated and shown to be

$$F = H \sqrt{\frac{2 W_0 A}{r}}$$

where H is the strength of the radial magnetic field, W_0 is the audio power transferred from the coils to the diaphragm, r is the superficial resistivity of the diaphragm and A is its area. The square of the force acting on the diaphragm is thus proportional to its area for definite values of H , W_0 , and r .

Returning to the equation of motion of the diaphragm we may calculate the power expended by the driving force $F \cos \omega t$.

$$\begin{aligned} \text{This is } W &= \frac{\omega}{2\pi} \int_0^{2\pi} \left[m \frac{d^2x}{dt^2} + k \frac{dx}{dt} + n^2x \right] \frac{dx}{dt} dt \\ &= \frac{k}{2} \left(k^2 + \left[\frac{n^2 - \omega^2 m}{\omega} \right]^2 \right) \end{aligned}$$

Estimation of n^2 for the diaphragm under consideration shows it to be entirely negligible compared to

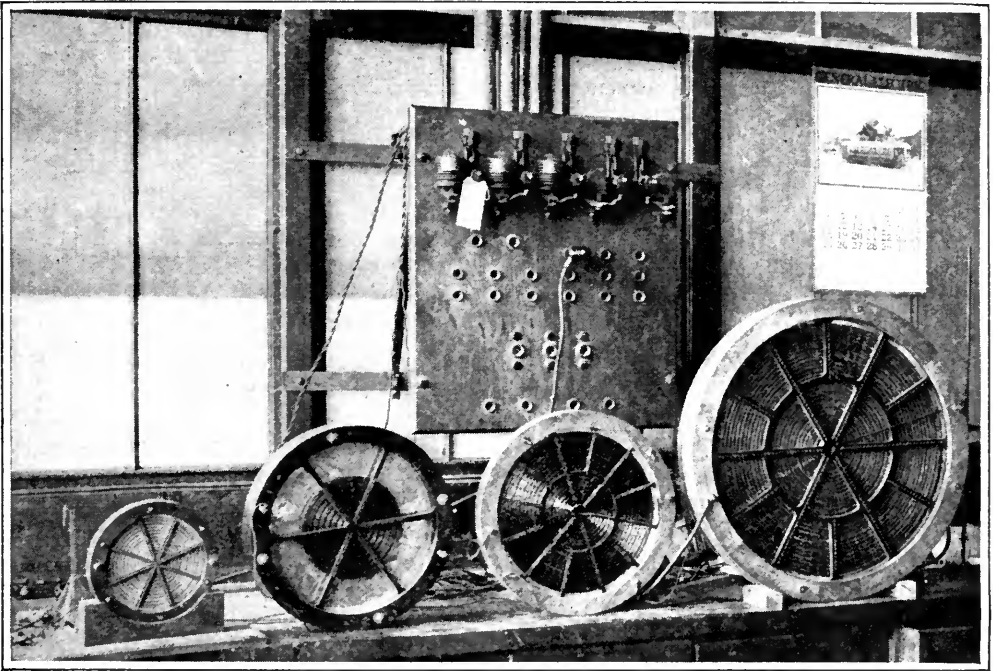

FIG. 2
Various size models of the induction loud speaker

$\omega^2 m$ for all frequencies with which we are concerned. The sound energy radiated each second then becomes

$$W = \frac{k F^2}{2 (K^2 + \omega^2 m^2)}$$

For very short waves this is radiated almost as a beam of plane waves of cross section equal to that of the diaphragm. As the waves get longer, the beam spreads out, and when the length of the waves is comparable to the circumference of the diaphragm the radiation passes out in all directions, and at the same time the above expression for W gives too large a value for the total radiation, because the diaphragm is not bounded by an infinite plane at rest. If a sound measuring device were placed in front of the vibrating diaphragm, and its indications taken for a wide range of frequencies, these indications would be proportional to W , calculated from the above expression, only for wavelengths short compared to the circumference of the diaphragm. For increasing wavelengths comparable to and larger than the circumference, the indications of the measuring instrument would increase less rapidly than W calculated from the above expression for two reasons. First, because on account of the greater spreading for long wavelengths a less proportion of the energy radiated would enter the measuring instrument, and second, because the expression gives too great a value for the radiation at long wavelengths. This consideration should be borne in mind when examining the tables and curves to

follow showing the sound energy radiated from the diaphragms as a function of the frequency.

CALCULATION OF SOUND RADIATION

THE sound radiation will be calculated for several different sizes of diaphragms. In order to make the results comparable, we shall assume that the radial magnetic field has the same strength for all sizes of diaphragm. As is shown in appendix III, this corresponds approximately to dissipating an amount of direct current power proportional to the square of the diameter of the instrument. We shall also assume that the same amount of voice-current power will be supplied to all sizes of instrument, that is, we shall employ the full output of a given audio amplifier to drive all instruments. As has been shown, this means that the force actuating the diaphragm is proportional to its radius. A comparison of the results so obtained will favor the smaller instruments from the standpoint of *total sound output*, for the radial field may be made stronger at a constant temperature of operation, and more audio power may be safely supplied to the larger than to the smaller instruments. With the same limiting temperature of operation the field of the largest instrument discussed might be from one to two times as great as that of the smallest, while the audio power input might be from ten to twenty times as great, so that the total sound energy output might be twenty to forty times as great in the case of the largest instrument. For any one instrument, however, these considerations would

not affect the relative amount of sound energy output at different frequencies. It might be remarked at this point that as the sound energy output is proportional to the product of the strength of the polarizing field, and the audio current in the diaphragm, and as the total power supplied is limited by the allowable temperature rise, the sound energy output is a maximum when the two powers are equal (see appendix IV). But owing to the great disparity in the cost of polarizing and audio power it is advisable to use polarizing power to within a small percentage of the allowable dissipation. For example, using the 25-inch instrument with 800 watts of polarizing power, and 30 watts of audio power, the sound pressure output is about 15 per cent. of what it would be using 415 watts of each kind of power.

VALUES OF DIFFERENT DIAPHRAGMS

THE calculation has been carried out for five different sizes of diaphragm assuming a uniform field strength $H=300$ gauss, and that the audio power input is 1 watt in each case.

The diaphragms are all of aluminum .025 cm. thick. The following table gives the results of the calculations and these are represented graphically in Fig. 4.

TABLE I

Radius	30	60	100	150	300
Frequency cycles/sec.	π cm.	π cm.	π cm.	π cm.	π cm.
	W in Kiloergs per sec.				
30		8.81	16.5	26.9	53.4
60	2.85	8.05	16.6	27.4	55.0
100	2.55	7.91	16.5	27.1	57.1
150	2.46	8.40	16.2	26.2	50.6
200	2.51	7.63	15.1	25.1	31.0
300	2.48	7.22	13.5	17.2	16.9
400	2.28	6.23	9.61	8.69	9.3
600	2.18	4.65	4.23	4.69	6.9
750	1.96	3.13	2.83		
1000	1.61	1.56	1.68		
1500	0.80	0.78			
2000	0.39				
3000	0.18				

As already stated, it should be borne in mind that the actual frequency characteristic as perceived by one standing in front of the instrument would not be so pronounced as indicated by the table and curves, because the calculation gives too great a value for the radiation at low frequencies; and also the lower the frequency the more the spreading of the sound. Moreover the response of the ear mechanism is proportional to the sound wave pressure rather than to the energy flux. At any given frequency the sound wave pressure is proportional to the square root of the energy flux. Still another consideration is the relation between the impedance of the amplifier and that of the loud speaker. Fig. 5 shows the impedance-frequency curve for the 25-inch or $R = \frac{100}{\pi}$ cm. instrument, provided with an aluminum diaphragm .025 cm. thick. The by-pass condensers shown in Fig. 3 were 3 mfd. each. It is apparent that if the power amplifier has an impedance of 1000

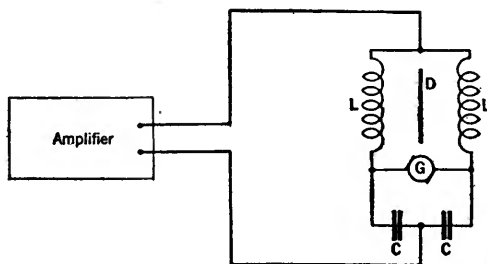

FIG. 3

The circuit diagram of the Hewlett induction loud speaker. L L are the two flat coils; D, the aluminum diaphragm; G, a direct current generator; and C C, by-pass condensers

ohms, then the power delivered to the loud speaker is going to fall off rapidly below a frequency of 600 cycles, which will prevent the excessive radiation of low frequencies. In fact, quite noticeable changes in the general pitch level of the reproduced speech of music can be accomplished by adjusting the impedance of the loud speaker by means of transformers. The difference in the directivity of the loud speaker for short and long waves is shown by the progressive loss in articulation, particularly with the larger instruments, as the angle between the axis of the instrument and a line drawn from the instrument to the observer is increased. When using the larger instruments out of doors and in auditoriums it is well to use at least two in order to so direct them as to minimize the effect just mentioned.

QUALITY OF THE SPEAKER ON LOW FREQUENCIES

IN ORDER to arrive at some idea as to how great an error is made in assuming for the purposes of calculation that the diaphragm is bounded by an infinite plane at rest, a large board, 6 feet square, was prepared with a circular hole of variable diameter in the center into which various size instruments could be placed. It was found with the smallest instrument, $R = \frac{30}{\pi}$ cm., the general pitch level of

speech and music was noticeably lowered when placed in the hole in the board, while with the instrument

$R = \frac{100}{\pi}$ cm. this lowering of the general pitch level

was barely noticeable. This means that, for the range of frequencies with which we are ordinarily concerned in the reproduction of speech and music, the failure of the expression for W at low frequencies is of little importance. Of course, there is still left the effect of the greater spreading of the lower frequencies.

On the whole, after taking everything into consideration, it appears that the instrument ought to reproduce well the lower frequencies which is necessary for naturalness in the reproduction of the human voice and for richness of quality in music. It is seen that the smaller diaphragms should give a fairly flat frequency characteristic over a greater

range than do the larger ones. That is, the higher tones should be relatively more important in the smaller than in the larger instruments. These conclusions are borne out by experience.

APPENDIX I

WE SHALL only attempt to get a rough estimate of the order of magnitude of the magnetic damping force acting on the diaphragm owing to its vibration across the radial magnetic field. For this purpose let us suppose that the metal composing the diaphragm is concentrated into a single circular turn of wire of circular cross section whose diameter is one half that of the diaphragm. Let this ring vibrate parallel to its axis with displacement x , velocity v and amplitude A . Then $x = A \sin \omega t$ and $v = \omega A \cos \omega t$. The induced electromotive force is $e = v c H$, where c is the circumference of the circular wire and H is the strength of the radial magnetic field. Then

$$e = \omega A c H \cos \omega t$$

$$= E \cos \omega t, \text{ where } E = \omega A c H$$

Applying Kirchoff's law, letting i be the induced current

$$i r + L \frac{di}{dt} = E \cos \omega t$$

where r and L are the resistance and inductance of the wire. From this follows

$$i = \frac{E}{\sqrt{r^2 + (\omega L)^2}} \cos(\omega t - \theta) \text{ where } \tan \theta = \frac{\omega L}{r}$$

The reaction of the field on this current is

$$f = i c H = \frac{\omega A}{Z} (C H)^2 \cos(\omega t - \theta)$$

where $Z = \sqrt{r^2 + (\omega L)^2}$

or

$$f = \frac{\omega A (C H)^2}{Z^2} \left[r \cos \omega t + \omega L \sin \omega t \right]$$

$$= r \left(\frac{C H}{Z} \right)^2 \cdot \frac{dx}{dt} + \omega^2 L \left(\frac{C H}{Z} \right)^2 \cdot x$$

In order to take account of this force, we may assume that this is the magnetic drag that would act on the diaphragm represented by the ring, and we may then add the above coefficients of $\frac{dx}{dt}$ and X to the corresponding coefficients in the original equation of motion. To carry this out for a particular case, the instrument $R = \frac{100}{\pi}$ cm. with an aluminum diaphragm .025 cm. thick was chosen. It is assumed that $H = 300$ gauss; calculation of the other quantities concerned give

$$r = 3.52 \times 10^6 \text{ e.m.u.}$$

$$L = 7.41 \times 10^2 \text{ "}$$

$$C H = 2.95 \times 10^4 \text{ "}$$

If we let $a = r \left(\frac{C H}{Z} \right)^2$

$$\frac{b}{\omega} = \omega L \left(\frac{C H}{Z} \right)^2$$

then the expression for the sound energy radiated is

$$W = \frac{k F^2}{2 \left[(k + a)^2 + \left(\frac{b}{\omega} - \omega m \right)^2 \right]}$$

The radiation in kiloergs /sec. and the amplitude in cm. calculated for this instrument for an input of 1 watt of audio power is given in table II.

TABLE II

FREQUENCY CYCLES /SEC.	W KILOERGS /SEC.	A CM.
30	16.9	1960 x 10 ⁻⁵
60	16.9	500 "
150	16.7	85 "
300	13.5	24 "
600	4.2	7 "

From a comparison of the values of W in Table II with those for the same instrument in Table I it is apparent that the damping of the magnetic field has no appreciable effect on the frequency-radiation characteristic of the loud speaker.

APPENDIX II

IN ORDER to get an approximate idea of the periodic force driving the diaphragm, let us assume that the audio power is transferred quantitatively to the diaphragm, and is there dissipated in heat. The audio impedance with diaphragm is only a few per cent. of that without diaphragm, and it is seen from Table I that with a field strength of 300 gauss somewhat less than 0.2 per cent. of the audio power is converted into sound radiation. The above assumption is, therefore, justified for a first approximation. We shall also assume that the induced current in the diaphragm is uniformly distributed. Let I be the maximum value of a sine wave audio current through an annulus of the diaphragm, 1 cm. wide, and let r be the superficial resistivity of the diaphragm. Let A be the area of the diaphragm, and W_o the audio power supplied. Then $I^2 r A = 2 W_o$, and the maximum value of

the force on the diaphragm is $H I A = H \sqrt{\frac{2 W_o A}{r}}$ where H is the strength of the radial magnetic field. For a given thickness of diaphragm of a given material, a given field strength, and a definite supply of audio power, the square of the force driving the diaphragm is proportional to the area of the diaphragm.

APPENDIX III

THE power dissipated in the instrument has to be eliminated through the faces of the coils, and in the absence of forced ventilation, the amount of power that can be dissipated from instruments of various size with a given mean temperature rise of the coils will be proportional to the area of the coils. The induction loud speakers have been designed to operate at a temperature of 100° C. The power to be dissipated is practically the polarizing power, since the audio power under actual conditions of operation is only a few per cent. of the

polarizing power. The following brief analysis will show the relation between the polarizing voltage, the number of turns, and the linear dimensions of the coils:

- Let R = radius of one pancake coil
- r = resistance one pancake coil
- t = axial depth of winding
- n = number of turns in one pancake
- E = voltage on one pancake
- S = space factor of windings
- ρ = specific resistance of the wire.

Let us assume a constant space factor for coil windings when using wire of various sizes, and for various size coils. This factor may vary from 0.40 to 0.50, and takes account of the thickness of insulation, the circular section of the wire, and the space between sections for the passage of sound waves.

$$\text{Then } r = \frac{\pi R n \rho}{R t s} = \frac{\pi \rho}{S} \cdot \frac{n^2}{t} = K_1 \frac{n^2}{t} \quad (1)$$

For the 25-inch instrument described in this paper, K_1 has a value of 1.31×10^{-5} at 20° C with r measured in ohms, and t in cm. This is a good representative value for K_1 and corresponds to a space factor of 0.426 and a specific resistivity of 1.78×10^{-6} ohms per cm^2 .

Equation (1) shows that the resistance of a pancake can be expressed in terms of the number of turns of wire and the axial thickness of the winding, independent of the diameter of the instrument.

The power dissipated in one pancake coil is

$\frac{E^2}{r} = \frac{E^2 t}{K_1 n^2}$. Let us suppose this proportional to the exposed area of the pancake coil. Then

$$\frac{E^2 t}{K_1 n^2} = K_2 R^2$$

When both pancakes are mounted together as they are in the assembled instrument, it is found that a temperature rise of 80° C corresponds to a value of $K_2 = 0.50$ when R is measured in cm., and the power in watts. $K_2 R^2$ then gives the power dissipated as heat in each pancake coil.

Solving the last equation for n we have

$$n = \frac{E}{R} \sqrt{\frac{t}{K_1 K_2}} \quad (2)$$

that is for a given operating voltage, the number of turns is proportional to $\frac{\sqrt{t}}{R}$. The current is $i = \frac{E}{r} = \frac{E t}{K_1 n^2}$

The ampere-turns for one pancake coil are $ni = \frac{E t}{K_1 n}$

and by Ampere's law, the strength of the radial component of the magnetic field contributed by one pancake is approximately proportional to $\frac{ni}{R} = \frac{E t}{K_1 n R}$

Let us see what condition must be fulfilled in order that we may have the same strength of magnetic field for instruments of all sizes, that is

$$\frac{E t}{K_1 n R} = K_3 \quad (3)$$

If E is expressed in volts, and the other quantities expressed as previously specified, then K_3 is approximately 1.6 times the strength of the radial component of the magnetic field due to one pancake, or 0.8 times the total radial component when both pancakes are present, the strength of the magnetic field being expressed in gauss.

Eliminating $\frac{E}{Rn}$ from (2) and (3) we have $t = \frac{K_1 K_3^2}{K_2}$

or the axial thickness of all the coils must be the same. Actually, the demands on the instrument from the standpoint of an audio transformer are such that the thickness of the coils may be made larger in the larger instruments than in the smaller ones. Therefore, with the larger instruments we may have a stronger radial magnetic field than with the smaller ones when operating at the same temperature.

In order to design the windings for an induction loud speaker, the following procedure will be found to be as direct as any. Suppose the approximate radius, R, of the pancake coils, and E, half the polarizing voltage, are given. First choose t, the axial thickness of the pancake, which may be 0.5 inches for coils as small as 4.5 in. radius to 1.0 inch for coils as large as 18 in. radius. Choose next, a space factor between 0.40 and 0.50. Calculate K_1 .

and take $K_2 = 0.50$. Then $H = \frac{K_2}{0.8} = 1.25 \sqrt{\frac{K_1 t}{K_1}}$

which should be at least as large as 280 e.m.u. If H is not this large, t or s should be adjusted

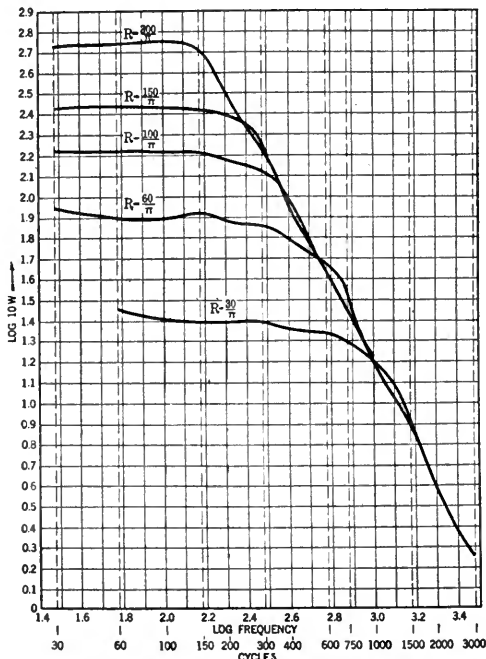

FIG. 4

accordingly. The resistance of the pancake coil is given by $\frac{E^2}{K_2 R^2}$. If d is the density of copper $\pi R^2 t S d$ gives the mass of copper in the pancake, and from this and the resistance, the size of wire to be used may be read off from a wire table. The number of turns may be calculated from equation (1). Using the above figures as approximations, the coil may now be accurately designed by obvious procedure. If the polarizing voltage is very low, say less than 100 volts, the instrument may require excessive current, and be of very low impedance, while if the voltage is high, the reverse conditions may be encountered. 250 to 500 volts for polarizing have been found to give very satisfactory results, both from the standpoint of polarizing current and audio impedance for all sizes of instruments so far built.

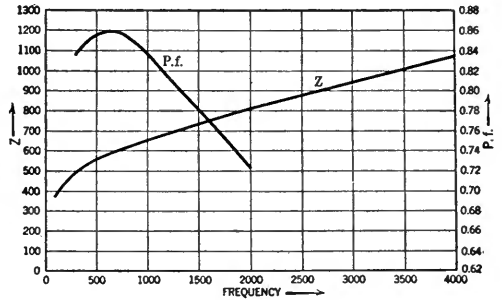

FIG. 5

$$2i_2 \frac{di_2}{di_1} r_2 + 2i_1 r_1 = 0 \tag{4}$$

From (4) we have $\frac{di_2}{di_1} = -\frac{i_1}{i_2} \cdot \frac{r_1}{r_2}$ (5)

Substituting (5) in (3) and equating to 0, we have $i_2^2 r_2 = i_1^2 r_1$, which is the condition that p shall be a maximum. It therefore follows that the audio and polarizing powers should be equal in order that the maximum sound radiation should be produced.

ACKNOWLEDGEMENTS

The writer wishes to gratefully acknowledge the helpful interest shown by Dr. W. R. Whitney throughout the development of this instrument. His ever present encouragement and faith is largely responsible for the successful outcome of this work. I wish also to take this opportunity to express my appreciation of many helpful suggestions from my colleagues Messrs. E. W. Kellogg, E. P. Lawsing, and C. W. Rice. The instrument described in this paper was invented in 1919 while the writer was teaching at the University of Iowa, Iowa City, Iowa. Its development described in this paper was carried out in the Research Laboratory of The General Electric Company, Schenectady, New York.

APPENDIX IV

LET us determine the condition for the maximum amount of sound radiation output for a given total amount of polarizing and audio power input. The force driving the diaphragm is directly proportional to the strength of the radial magnetic field, which in turn is directly proportional to the polarizing current i_1 . The force is also proportional to the audio current in the diaphragm, which in turn is proportional to the audio current in the coils i_2 . The sound pressure output p is proportional to the force acting on the diaphragm and, therefore, we may write

$$p = K_1 i_1 i_2 \tag{1}$$

If r_1 and r_2 are the d-c and audio resistances, respectively, of the instrument, then the condition that the total power supplied shall be independent of the relative proportions of polarizing and audio powers, is

$$i_1^2 r_1 + i_2^2 r_2 = K_2 \tag{2}$$

differentiating (1) and (2) with respect to i_1 , we have

$$\frac{dp}{di_1} = K_1 i_2 + K_1 i_1 \frac{di_2}{di_1} \tag{3}$$

NEUTRALIZING AND TUNED RADIO FREQUENCY

ANOTHER paper presented before the Radio Club of America will appear in RADIO BROADCAST for September. It is by C. L. Farrand and deals with his further findings in the field of tuned radio frequency amplification, especially in the important matter of neutralization. The progress of Mr. Farrand's experiments is traced and diagrams and photographs show clearly his research in this very important subject.—THE EDITOR.

Making a "Super-Het" From Your Neutrodyne or Single-Circuit Set

How to Apply the Frequency-Changer to Two Very Popular Types of Receivers, Resulting in Greater Receiving Range and Sharper Tuning

BY A. O'CONNOR

QRADIO constructors and radio operators everywhere have long been interested in some method which would permit them to add a device to their set which would make it into a super-heterodyne. That receiver still stands as one of the most sensitive and desirable from many points of view. In RADIO BROADCAST for June, Mr. O'Connor described the details of construction of the Frequency-Changer developed by him, and in this article, his very clear instructions tell just how it may be applied to a single-circuit or a neutrodyne receiver. The first article aroused a great deal of interest, and we feel sure that this one will appeal to a great number of broadcast listeners who want the well known benefits of super-heterodyne reception.—THE EDITOR

THE ambition of many owners of receiving sets to own a super-heterodyne has been deterred for several reasons, chief of them being the high cost and because the owner of an already existent receiver did not feel like disposing of it at a sacrifice. In RADIO BROADCAST for June the writer described a simple one-tube Frequency Changer that could be added to any receiver, thereby converting it to a most efficient and inexpensive super-heterodyne. And after constructing such a unit, the first thought in the builder's mind must be the question of applying it to the receiver he owns.

Perhaps the simplest place to utilize this Frequency-Changer is in connection with the simplest known receiver, the single-circuit "blooper." This type of receiver being, probably, more generally owned than any of the others, it seems logical to show the tricks that must be performed with the blooper before it is a "super."

Briefly, the Frequency-Changer is a device for heterodyning incoming signals and passing them on to the intermediate-frequency amplifier at a greatly changed frequency. The intermediate amplifier consists of the present receiver, and the changing of frequencies takes place in the unit described in this magazine for June.

As stated in the first article of the series, the unit will increase the volume of signals, will enable any receiver to reach out to greater distances, will add greatly to the selectivity of the existing receiver, and will be an aid

toward preventing radiation. Due to the fact that the beat frequency generated in this unit is very high, compared to the usual super-heterodyne, stations will appear only once on the tuning dials, an advantage that will appeal to all those who like ease of tuning.

ADVANTAGES OF THE FREQUENCY-CHANGER

ANOTHER advantage of this addition to any receiver lies in the fact that all tuning is done on the Frequency-Changer, and none on the receiver. This feature is particularly important to users of neutrodynes and the more complicated four- and five-tube receivers, for with the addition of the unit, tuning controls have been reduced to two. The dial numbers will be essentially alike at all broadcasting frequencies, and may be calibrated.

Fig. 1 is a schematic diagram of the Frequency-Changer, and Fig. 2 is a photograph of the completed unit, both illustrating the simplicity of the device. Fig. 3 represents the more usual types of single-circuit receivers, and the methods of attaching the Frequency-Changer unit to them.

There is only one difficulty in connecting the unit to such receivers, and that lies in the fact that it is possible to short-circuit the 45-volt B battery which is connected in the output of the unit. This can be prevented by simple precautions. The grid circuit of some types of this regenerative receiver is connected to the negative B and since the Frequency-Changer is connected to plus B there is the possibility of short-circuiting the B battery.

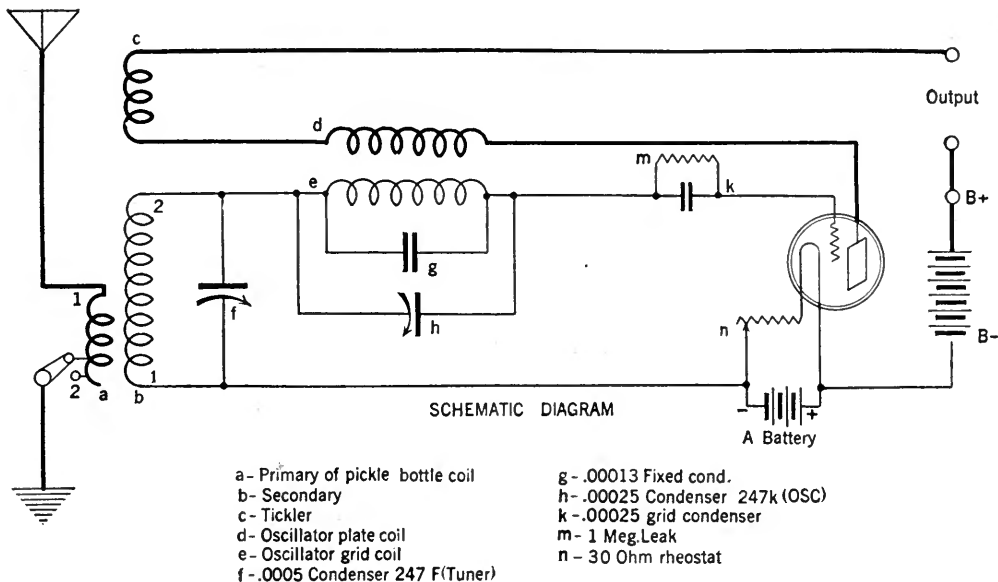

FIG. 1

The Frequency-Changer unit that may be added to any receiver to make it into a super-heterodyne

This is illustrated A and in B of Fig. 3 and the method of avoiding trouble is shown. In A, the method consists of winding a small coupling coil of 6 turns of No. 20 double silk covered wire around the grid coil of the receiver and insulating the two windings by a layer of empire cloth or tape. The antenna and

ground connections are then connected together. In B, the method is simpler, since it is only necessary to cut the connecting wire between the small primary coil and the secondary winding.

The matter of selection of the type of tube is not highly important, since any of the standard

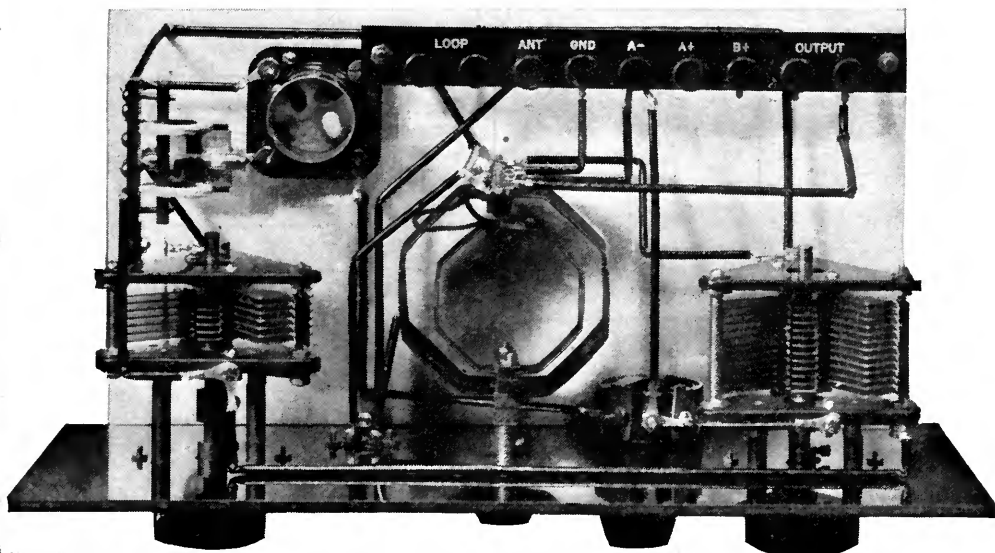

FIG. 2

The disposition of the parts and the simplicity of the wiring may be seen from this photograph which looks down upon the Frequency-Changer. How to build this unit was described in RADIO BROADCAST for June, 1925

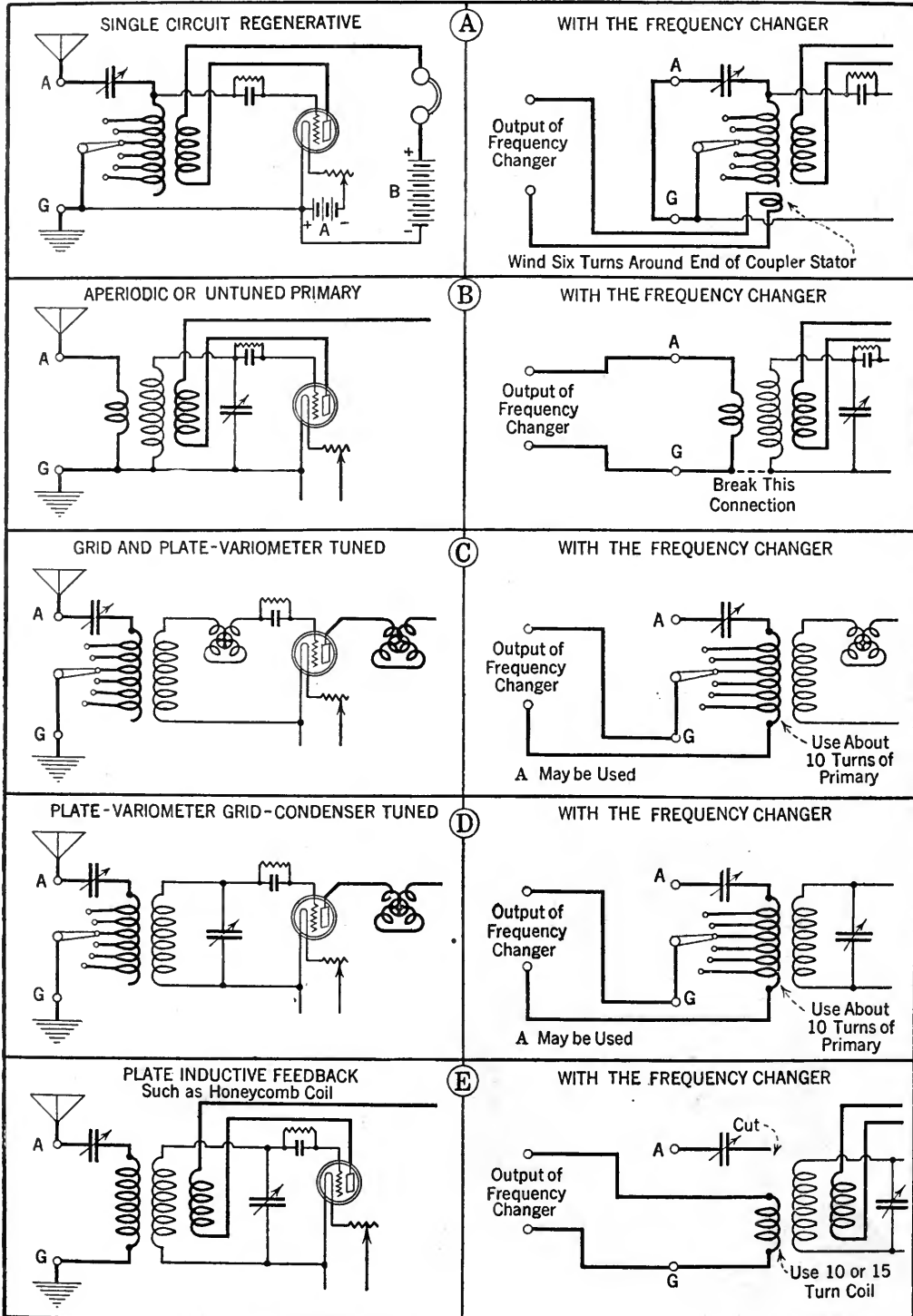

FIG. 3

Here is the whole family of single-circuit bloopers together with the methods of attaching the Frequency-Changer to them. In A and B are two methods of avoiding possible short-circuiting of the B battery

tubes will work properly. As a matter of fact, the 6-volt type is best, the 3-volt type second, and the $1\frac{1}{2}$ -volt tubes a fair third. The operation of the Frequency-Changer and the receiver to which it is attached, is a simple matter. It is only necessary to tune the receiver to 600 meters or as near to it as possible, and crank up the regeneration to a point where considerable gain is evidenced, but not so far that oscillations actually take place. Once the tuning dial is set at 600 meters or near it, it will not be necessary to touch it again, since all tuning is done with the Frequency-Changer dials.

Both dials of the Frequency-Changer will tune nearly alike, and the tuning is sharp enough to demand a good vernier dial. Those on the Frequency-Changer illustrated in the photographs are Velvet Vernier dials made by the National Company, Inc. of Cambridge, Massachusetts.

WHY THE RECEIVER IS TUNED TO 600 METERS

THE object in using 600 meters is to place the intermediate-frequency amplifiers above the broadcasting wavelength bands to avoid interference. If the receiver will not tune high enough, a small fixed condenser, of, say .0001 mfd. capacity, may be placed across the tuning condenser, and the receiver tuned to some point well above the longest broadcasting wavelength. Many ocean vessels use the 600-meter band for ship to shore communication and one method of tuning the receiver to this wavelength is by listening for code signals. The exact wavelength is not important, as long as it is out of the broadcasting band.

In case no heterodyne action is noted, it may be necessary to reverse the connections to one of the two coils in the oscillator coupler,

and for best operation it is well to try reversing the output connections from the Frequency-Changer.

The tickler of the pickle bottle coil will give regeneration which will be especially useful on distant stations, as well as sharpening up the tuning. If the coupling of the two oscillator coils is correct, the tickler of the pickle bottle coil will just cause oscillations when KSD or some other high wavelength station is tuned-in. With this setting, the tickler will not have to be adjusted more than three times when going down toward the lower wavelengths. Thus there are only two tuning controls.

In order to get maximum selectivity, a selector switch has been added which makes it possible to use three or six turns in the primary of the Frequency-Changer. The smaller number of turns may decrease signal strength somewhat but will enable the operator to cut his way through interfering stations with greater freedom.

One of the important points about this device when added to a single-circuit blooper is the fact that the blooper may oscillate without its radiation getting to the antenna. These oscillations are confined to the receiver itself, and do not pass through the Frequency-Changer to get out on the antenna. It is possible to tune-in stations by the usual "squeal" method, without annoying the neighbors—a most important point.

GUARDING AGAINST RADIATION

THE oscillator circuit itself does not radiate, and there is only one other adjustment that is liable to disturb the neighbors. If the tickler of the Frequency-Changer is turned until a click is heard in the phones, the Fre-

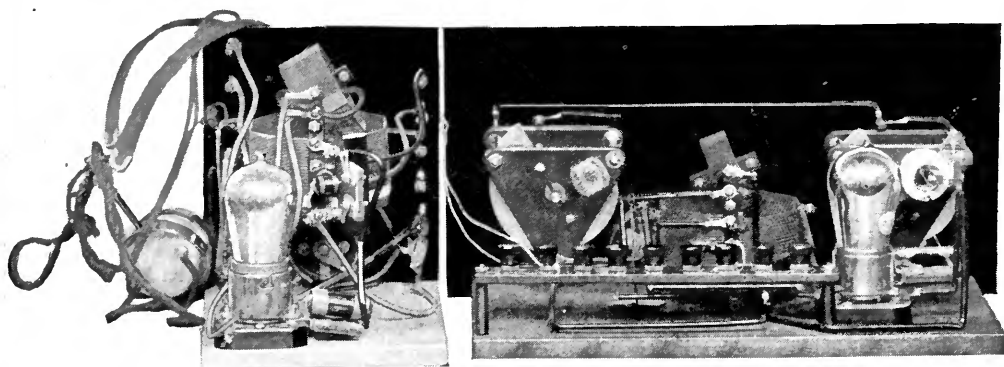

FIG. 4

Here is a two-tube super-heterodyne made by adding the Frequency-Changer to a single-circuit tickler feedback receiver. The addition of the Frequency-Changer improves the selectivity, adds distance, and eliminates all possibility of the receiver radiating into the ether

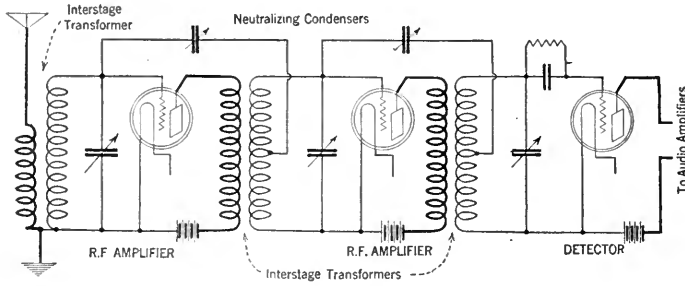

FIG. 5

This is the conventional neutrodyne diagram of connections. Without the neutralizing condensers it would represent the connections for the first three tubes of the usual five-tube tuned radio frequency receiver

frequency-Changer is oscillating at the frequency of the incoming signals and will radiate at this frequency. But the minute this occurs, the whole system becomes inoperative, no signals get through to the loud speaker or head phones, and the operator naturally turns down the tickler. For this reason, the danger of parasitic oscillations going out into the ether is remote, and at any rate will only last a second or two.

When attached to a single-circuit receiver as shown in Fig. 4, the two tubes make phone reception from distant stations easily possible. With the addition of two amplifier tubes, loud speaker operation in Cleveland was possible from WHAS on 750 kilocycles (399.8 meters) and WGY on 790 kilocycles (379.5 meters) when WEAR or WTAM on 770 kilocycles (389.4 meters) were operating, and without hearing the local stations at all. Equal selectivity was enjoyed in the Laboratory of RADIO BROADCAST although the "local" stations in this case were about 20 miles away. KSD, St. Louis, was heard in Garden City while New York stations were operating. This was an indication of the sensitivity of the receiver since KSD is rarely heard in the

receiver, and without some of the disadvantages that both the neutrodyne and "superhet" possess. With the addition of the Frequency-Changer, the neutrodyne, whether it is good, bad, or indifferent, lifts its head and becomes a full fledged "super" with two stages of neutralized intermediate frequency amplification, and if the audio frequency transformers are good, and provided that the proper C batteries are used, the six tubes then in operation will provide a receiver that will be hard to beat.

In Cleveland the average neutrodyne will not tune sharp enough to approach within 50 meters of local stations without interference. Although other stations may be heard the local is heard also, and "we don't count them, if we hear the local." A Frequency-Changer added to a four-tube reflexed neutrodyne, such as the Fada four-tube, or the Ware, or others, and operating on a long antenna has so improved selectivity that WGY and WHAS (whose wavelength is 10 meters from locals) can be brought in without interference from WTAM or WEAR. Attaching the Frequency-Changer to a five-tube set enables the operator to use a loop, and under these conditions, stations in Philadelphia (whose wave is 5 meters wavelength away from locals) may be picked up without local disturbance. The reflexing feature seems to make no difference in the selectivity of the outfit, but the loss in volume is clearly noticeable.

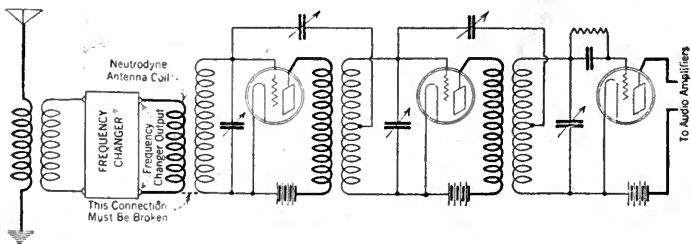

FIG. 6

The addition of the Frequency-Changer to a receiver like that of Fig. 5 is a simple matter as this diagram shows. It is important that the connection indicated be broken to avoid shorting the B battery

Laboratory under the best conditions.

THE FREQUENCY CHANGER APPLIED TO NEUTRODYNE

BY FAR the greatest application of the Frequency-Changer is in connection with the many neutrodyne receivers. There are possibly 400,000 of these receivers in the United States, and each of them is a potential superheterodyne with all of the advantages of this selective

Tuning is sharper when using a loop, although some volume is naturally lost. A five-tube neutrodyne with a Frequency-Changer at-

tached to a collapsible loop has picked up California from Cleveland during the month of February, although this is to be regarded as a stunt, and not regular performance. One thousand mile reception in favorable weather is the usual range of such a hook up.

Let us examine the neutrodyne circuits and apply the Frequency-Changer to them. Fig. 6 illustrates the essential connections of a five-tube neutrodyne set. Fig. 7 shows a tuned radio frequency set with a Frequency-Changer added to it. The output circuit of the Frequency-Changer is connected only to the aperiodic primary of the first neutroformer. In a neutrodyne set, the primary is usually connected to both negative A and ground, and it is absolutely necessary to disconnect the negative A connection as we did with the single-circuit set. This will eliminate all danger of short-circuiting the B battery which is connected through the output circuit of the Frequency-Changer.

VARIOUS TYPES OF NEUTRODYNES

SOME neutrodyne sets have but one winding in the first transformer, the antenna and ground being connected to taps on this winding as shown in Fig. 8. This method of getting coupling to the antenna cannot be used in connection with the Frequency-Changer due to the fact that the output of the unit carries 45 volts of B battery. A pair of phones and a small battery, such as a C battery, or a few volts of B battery are all that is necessary to ascertain whether such a coupling method is used or not. The phones, battery and antenna may be connected in series, and the remaining wire touched to the filament of the first tube, as shown in Fig. 9. If a click results, it is evident that the antenna binding post is connected to the first coil and naturally through the wiring back to the B battery.

An additional winding must be used in

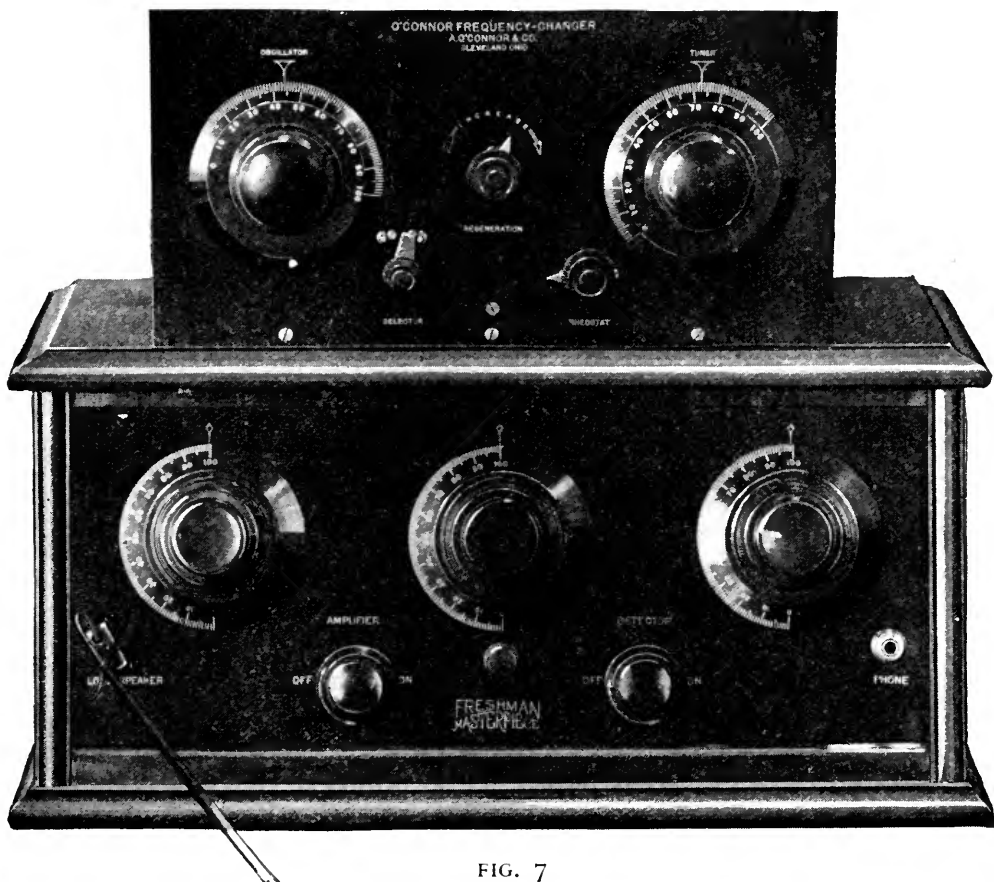

FIG. 7

With the addition of the Frequency-Changer to any of the well-known neutrodynes, or the radio frequency receivers, the owner has an excellent six-tube superheterodyne that may be operated on a loop from medium distant stations. The receiver illustrated here is a well-known five-tube radio frequency set

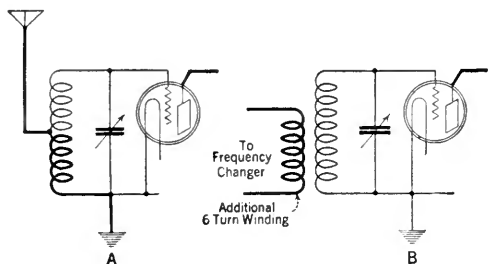

FIG. 8

It sometimes happens that the antenna is connected to the receiver as shown in A of this Figure and the method of adding the Frequency-Changer is illustrated in B, where a few turns of wire are wound around the grid coil of the first tube

such cases and the method of connecting it into the circuit is shown in Fig. 10 where an aperiodic winding of six turns of No. 20 d. s. c. wire are wound on the outside of the coil and separated from it by a thin layer of empire cloth.

A GREAT many neodyne sets are perfectly neutralized, and in this case the operation will be all that can be desired. The great majority, however, might be better neutralized and the sets oscillate when being tuned. If such a receiver oscillates at present (squeals when tuning), we would advise adding a 200-ohm potentiometer, as is illustrated in Fig. 10. When the arm on the potentiometer is rotated toward the negative A binding post, the set will operate as it did before the potentiometer was added, and will oscillate. By turning the arm away from negative A a very short distance, the oscillations will cease and perfect tone will result.

Tuning is done in exactly the same manner as with the single-circuit regenerative receivers. If it is known that your set will tune up to 600 meters, set all three dials at the point where 600-meter stations are tuned-in. The

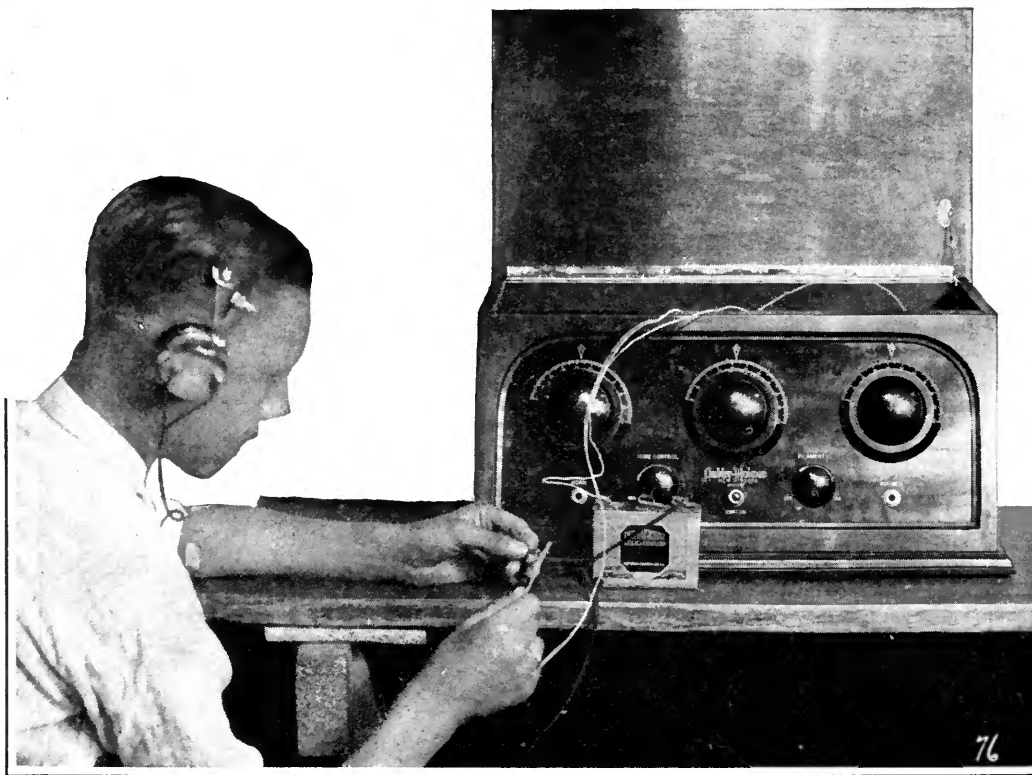

FIG. 9

A pair of phones and a battery are all that are needed to determine whether the receiver is wired like that in Fig. 8. One of the wires going into the cabinet is connected to the antenna binding post and the other to the grid coil of the first radio-frequency amplifier tube. If there is a click it demonstrates that the antenna is directly connected to this first coil

three dials of a neutrodyne set run fairly close together and the change in wavelength per dial degree will enable the operator to determine just where to tune for 600 meters. For instance, let us suppose that two stations near the top of the condenser dial are 20 meters apart, representing a change of 4 degrees on the dial. Then each degree represents 5 meters change and it is a simple matter to calculate where 600 meters will be. Now pick up stations on the Frequency-Changer and check with the calibration chart in the next column. If stations are considerably below the reading on the chart, it will be necessary to tune your neutrodyne still higher. A strong oscillation point may be found at the upper

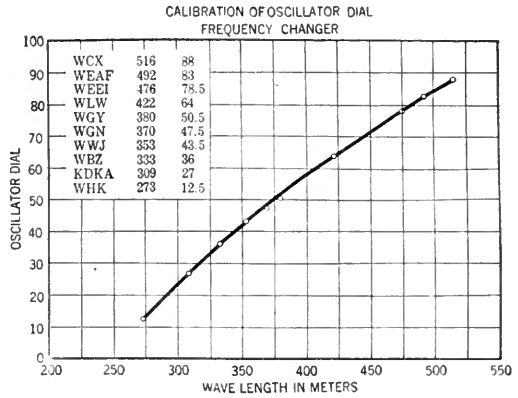

FIG. 11

This chart shows the relation between the oscillator dial numbers and the wavelengths to be received. If the intermediate amplifiers are tuned to 600 meters, the tuner dial figures will be very near those shown on this chart

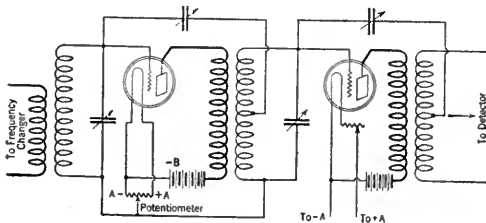

FIG. 10

If the neutrodyne or the tuned radio frequency set has a tendency to oscillate when in tune, the addition of a potentiometer will aid in controlling the amplifiers. The method of making this addition is illustrated in this Figure

part of your oscillator dial. This means that the Frequency-Changer is interfering with the neutrodyne setting. By tuning the neutrodyne up to 600 meters this oscillation point will be eliminated. If the receiver will not tune to 600 meters, connect a .0001 mfd. fixed mica condenser across the three variable condensers, which will effectively increase the upper tuning range.

W. R. Bradford

READERS of RADIO BROADCAST read with much sympathetic interest and the tribute of an earned smile the article by W. R. Bradford. "Radio Heaven Via the Roberts Circuit," March, 1925. His cartoons we have used were popular too. The cartoon at the right was sent in to us just a short time ago by Mr. Bradford from his Philadelphia headquarters at the *North American*. Mr. Bradford was a great booster for the Roberts circuit with which he had great success.

After a short illness, Mr. Bradford died at his home in Philadelphia, on the 6th of June. He had been for a number of years, cartoonist on the *North American* and within the past eight months had been radio editor of the same paper. RADIO BROADCAST records the death of Mr. Bradford with the knowledge that newspaperdom has lost an able cartoonist and writer. Radio enthusiasts have lost from their ranks a genuine and earnest experimenter.

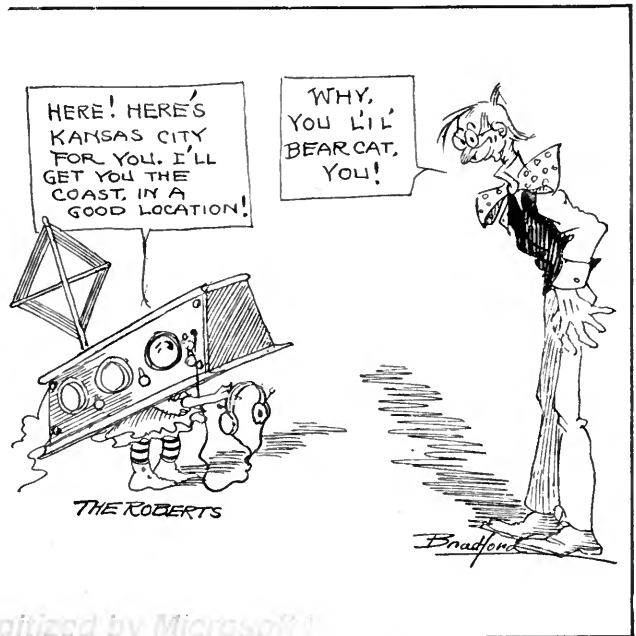

Coils and Condensers

A Discussion of Present Tendencies of Radio Design as Evidenced by Tuning Apparatus Produced by Well Known Radio Manufacturers—Two New Receivers

By THE LABORATORY STAFF

THE RADIO BROADCAST Laboratory was founded for two reasons, to protect its advertising pages and to provide a fund of information upon which our readers might draw. The purchaser of radio equipment has little chance to find out what is wheat and what is chaff among the material that is for sale—that has become the task of the Laboratory. Whatever information it has, will be contained in these pages for the benefit of our readers.

It is obviously impossible to test in the Laboratory, or to illustrate, or even to mention all radio equipment that appears for sale. Last year there were 400 manufacturers of condensers alone and to test all of their products would make it impossible for the Staff to know about anything else.

The apparatus illustrated or mentioned in these pages is neither all that is tested in the Laboratory nor what the Laboratory believes to be the best on the market—it is merely representative equipment. It is obvious that nothing in which the Laboratory does not believe will be described, nor will advertisements of poor apparatus coming from unreliable concerns be included in the magazine.—THE EDITOR.

THE tuning elements—coils and condensers—are, perhaps, as important as any apparatus that goes into radio receivers. Upon them depends the strength of signals and the selectivity of the receiver. The quality of reception depends upon other apparatus.

Much effort has been spent in making good condensers, and it is probable that the ultimate has been reached in "low loss" condenser design. Several important trends are to be noted among condenser manufacturers. The first is the attempt to make condensers of "low loss," the second is the tendency toward "straight line" wavelength or frequency curves, and the third is the advent of condensers and dials which turn through 360 degrees instead of the orthodox 180 degree instruments.

Readers interested in the low loss business, will do well to read the results of work done by Sylvan Harris and published in the Proceedings of the Institute of Radio Engineers for February, 1925. An abstract with the available facts has been placed in a small booklet by the Rathbun Manufacturing Company which shows that practically all modern condensers are "low loss"; in other words, one is as good as another as regards electrical efficiency. The figures show that there is little, if any, difference between condensers with metal or composition end plates, although it may be significant that practically all of the manufacturers are using metal end plates—and that the General Radio Company, one of the oldest builders of quality radio equipment, uses composition plates.

The tendency toward condensers that distribute the broadcasting stations evenly over the entire dial is much to be desired.

In the older condensers, the capacity varied directly as the angle through which the plates

turned, so that the relation between the marks on the dial and the capacity of the instrument could be represented by a straight line. This condenser bunches the stations operating on high frequencies (low wavelengths) and spreads apart those on the lower frequencies, an obvious disadvantage, since there are more stations on the higher frequencies.

There are two methods of avoiding this difficulty. One is to make a condenser which will distribute all stations according to their wavelengths, and the other is to distribute them according to their frequencies. In other words if Class B stations are 10 kilocycles apart in frequency, they will be a certain number of condenser degrees apart whether they are at the high or low end of the frequency gamut.

There is little difference between these two methods of attaining the same object, except that it is simpler to talk frequencies and more scientific—when we all get used to it.

The shape of the plates determines the capacity curve, and many and strange are the modern condenser plates. Some manufacturers make them strange to begin with, while others cut holes in an ordinary semi-circular plate. The cutting away of an orthodox plate is the usual method, and the Kellogg, the newer General Radio, or the Lacault condensers show this method. The business of carving something from the center of the plate is shown on our photograph by the New York Coil Co. The Rathbun condenser has part of the plate interior cut away, although the illustration does not show it.

The third factor in modern condenser design, the 360-degree dial is important. Instead of grouping the eighty-odd Class B and innumerable Class A stations into half a dial, or 180 degrees, they are

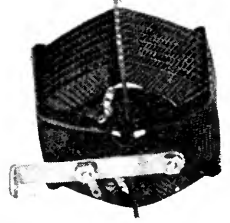

1

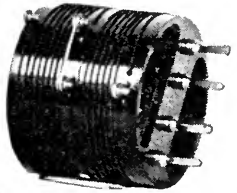

2

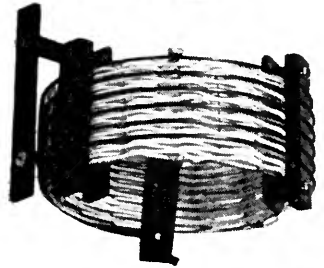

3



4

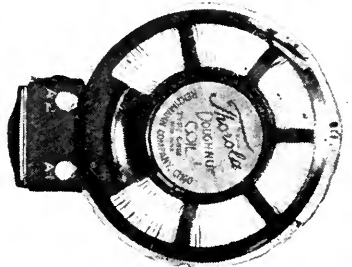

5

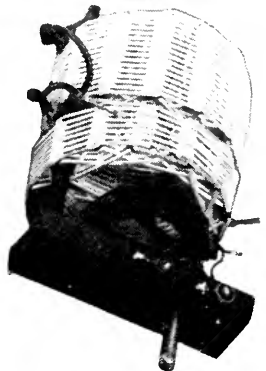

6

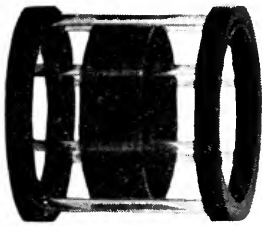

7

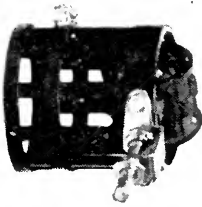

8

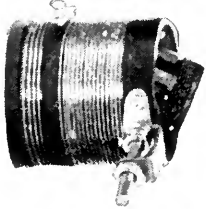

9

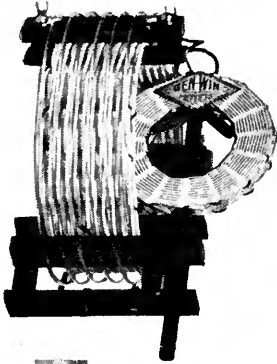

10

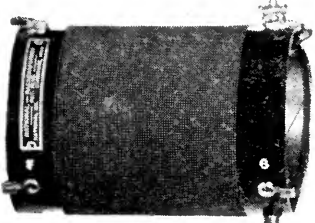
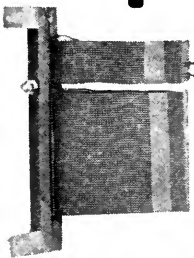

11

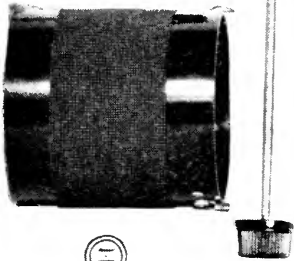

12

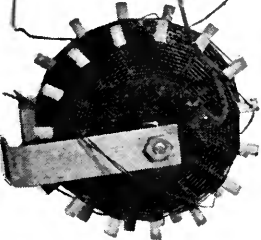
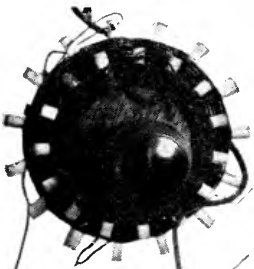

1. RADIO UNITS, Inc., Maywood, Ill.
2. GENERAL Radio Co., Cambridge, Mass.
3. GLOBE Radio Equipment Co., New York City.
4. RADIO FOUNDATION, Inc., New York City.
5. REICHMANN COMPANY, Chicago, Ill.
6. PERFECTION Radio Mfg. Co., Philadelphia, Pa.
7. BRUNO Radio Corporation, New York City.
8. AMBASSADOR SALES CO., Inc., New York City.
9. GENERAL Radio Winding Co., New York City.
10. EASTERN COIL CORPORATION, New York City.
11. NATIONAL Co., Inc., Cambridge, Mass.
12. VICTOR Radio Co., Philadelphia, Pa.

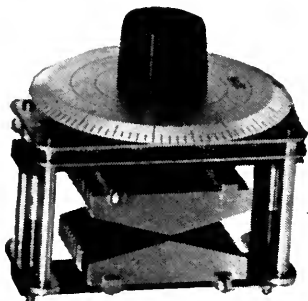

(5)

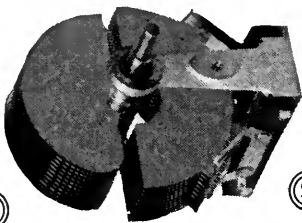

(10)

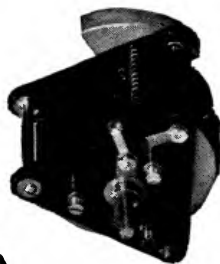

(12)

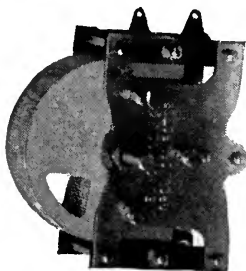

(4)

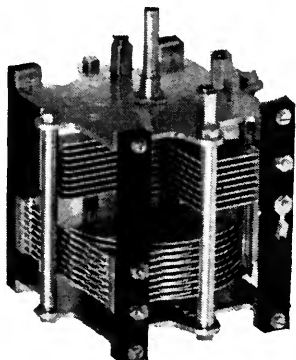

(9)

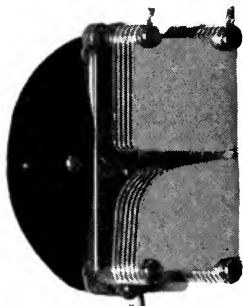

(3)

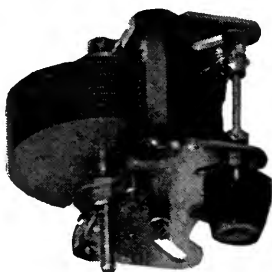

(8)

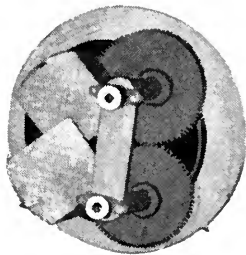

(2)

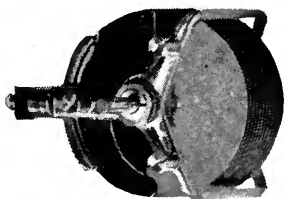

(7)



(1)

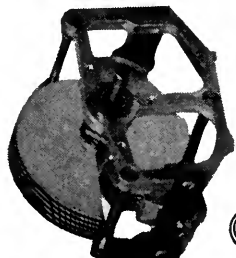

(6)



(11)

1. RATHBUN Mfg. Co., Jamestown, New York.
2. KEMLER RADIO Mfg. Co., San Francisco, California.
3. NELSON TOOL CO., INC., New York City.
4. NEW YORK COIL CO., New York City.
5. WADE Mfg. Co., New York City.
6. BREMER-TULLY Mfg. Co., Chicago, Ill.
7. PHENIX RADIO CORPORATION, New York City.
8. AMERICAN BRAND CORPORATION, Newark, N. J.
9. THE ALLEN D. CARDWELL MFG. CORPORATION, Brooklyn, N. Y.
10. KELOGG SWITCHBOARD & SUPPLY CO., Chicago, Ill.
11. BARRETT & PADEN, Chicago, Ill.
12. GENERAL RADIO COMPANY, Cambridge, Mass.

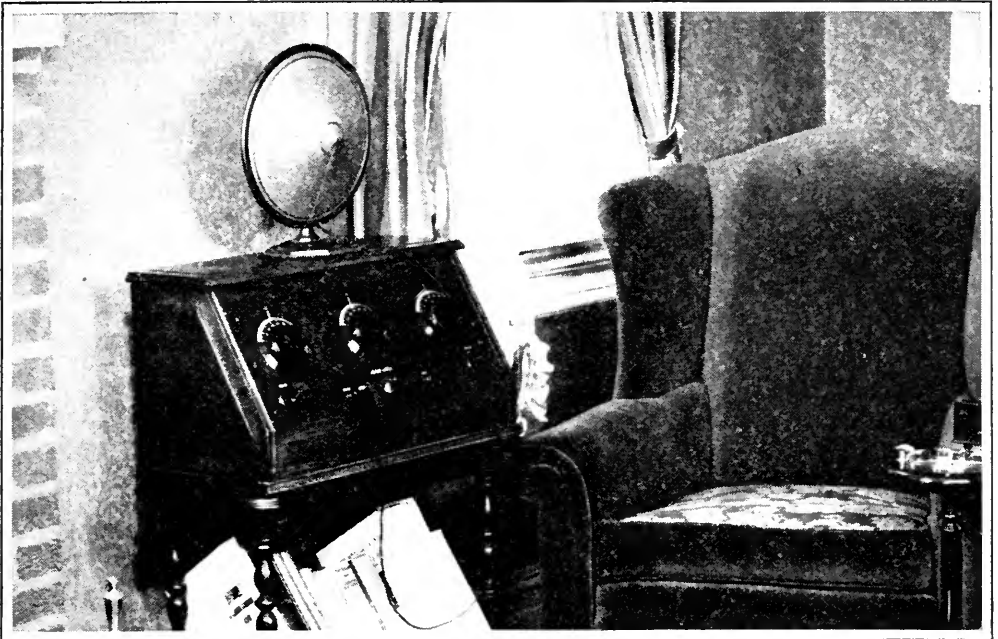

TWO NEW RECEIVERS

These receivers mark the entry of two well known manufacturers into the radio field. The lower photograph is that of the Stromberg Carlson Neutrodyne, a five-tube receiver that conforms to the best type of home decoration, and in the Laboratory proved itself to be an excellent receiver. The loud speaker is also from Stromberg Carlson. The upper receiver is made by Stewart Warner, manufacturers of a complete line of radio equipment, including tubes. This receiver is a five tube, tuned radio frequency amplifier set and is housed in a beautiful cabinet

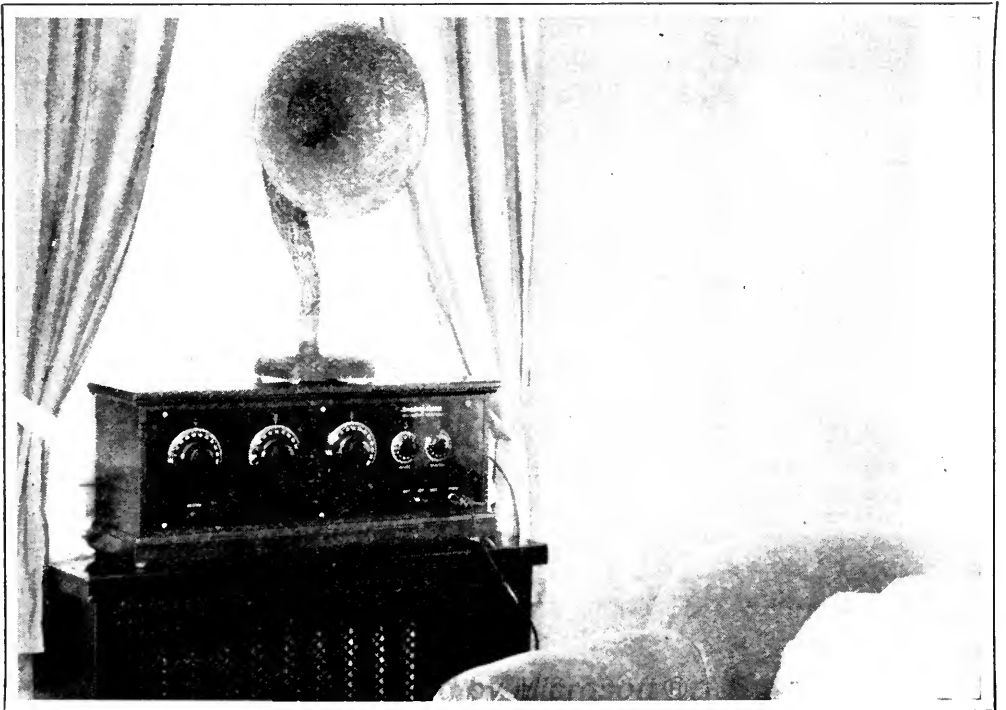

distributed around the circumference of a complete circle with somewhat greater ease of tuning.

WHAT IS A GOOD COIL?

COILS have come in for their share of attention too, although it must be said that it is a much greater task to build an efficient coil than an equally efficient condenser.

A coil has but one purpose in a receiver, and that is to furnish inductance to the circuit. Unfortunately it also has resistance and capacity, neither of which is desirable.

A good coil then, has a maximum of inductance, a minimum of resistance and a minimum of capacity. The first two determine the selectivity of the receiver and the strength of signals. The capacity of the coil determines the highest frequency (lowest wavelength) that can be received with a given condenser.

All coils have a magnetic field surrounding them. This field is usually useful but does a lot of things it should not, and is difficult to measure. In general, the larger the field, the more space the coil requires, the greater will be the losses in the coil when in a receiver, and the greater will be the danger of unwanted coupling with other parts of the circuit.

When a coil comes to the Laboratory, the first thing that is done is to measure its inductance, then its resistance at various broadcasting frequencies is determined, and then its relative efficiency determined. Unfortunately, these measurements are not the same when the coil is actually in circuit, but are a good measure of how well it will work in a receiver. Never yet has a coil that was poor in Laboratory measurements proved to be excellent when in actual operation.

Coils of all types, solenoid, spiderweb, basket weave, what not have been tested. If they were wound with average sized wire, with a minimum of dielectric and without "stickem" to hold them together their losses were about equal. It is probable that the best type to-day is the old fashioned solenoid wound on "air", with the basket weave made with many pegs—so that it approaches a solenoid—a close second.

Spacing between turns is more important than most manufacturers realize, though the coils made by the National Company and wavemeter coils made by the General Radio Company, reduce losses made by this method. Elimination of dielectric is necessary for a coil to have very low losses. The use of large wire does not seem to reduce losses but it adds mechanical strength, an important point.

Skeleton forms made by the Ambassador Sales Co. Inc., and the Bruno Radio Corporation, are now available and if the wire wound on them is slightly spaced it is doubtful if better coils can be made by the home constructor.

TOROID COILS

WITHIN the last few months a new type of coil has appeared that offers much for radio. This is the "toroid" coil and is designed to have a small external magnetic field. This small field makes it possible to place the coil near metal plates

without the usual increase of coil resistance. This means that a receiver may be made more compact.

Since the external field is small, signifying that little gets out of the coil, it follows that little will get into it from the outside through unwanted coupling. For this reason two coils may be placed close together without regard to the angle between them. Signals will not be impressed upon a part of a circuit except through the channel provided for it to follow.

At the same time it should be possible to build a coil that will not fall below the standards of a good solenoid—especially when placed in the circuit where it is to be used.

Unfortunately there are some disadvantages to the toroid coil, for they cannot be tapped, for this destroys the toroid effect. It is difficult to get energy into the coils, except through the use of external coupling coils which may introduce both resistance and capacity—both of which decrease the efficiency of the coil. Regeneration must be added to a circuit through capacity feedback instead of the customary tickler. There is nothing wrong with this system except that it is unusual and not so well understood by the average constructor.

The Laboratory believes that the toroid coil is an important development in the proper direction, and specimens made by the Pathé Phonograph and Radio Corporation, The Electrical Research Laboratories, and the Reichmann Company have been interesting and efficient inductances.

A useful dial recently added to the General Radio line and the American Brand worm geared condenser are devices that will make tuning a simpler problem.

THE COMBINATION OF COIL AND CONDENSER

THE combination of a coil and a condenser is the fundamental unit about which the entire receiver pivots, and a purchaser of such tuning elements should know that he is getting the best.

Condensers have been developed until there is little more to be expected in the way of eliminating losses. The "straight line" vogue is worth while. Condensers which have 360-degree tuning dials and which are illustrated in this article are made by Remler, Nelson Tool Co., Wade, and Barrett and Paden. The tandem condenser made by Cardwell and others is interesting in connection with increased simplicity of tuning, because two or more units can be operated on one shaft.

For some time it has been realized that coils could be improved, and the newer inductances wound with a minimum of dielectric, of fairly large wire, with space between turns, are steps in the right direction. Basket weave coils made by the Perfection Co., the General Winding Co., and the Globe Radio Equipment Co., have very low losses. The "baby" coil of the Ambassador Sales Co., is designed for the short waves and with a .0005 mfd. condenser, tunes from 50 to 150 meters. Basket weave coils, similar to those illustrated, but for the short waves are made by A. C. Lopez & Co., of New York City. The "Paddlewheel" coil made by Radio Units Inc., is a distinctly different type, and is effectively used in the Deresnadyne receiver.

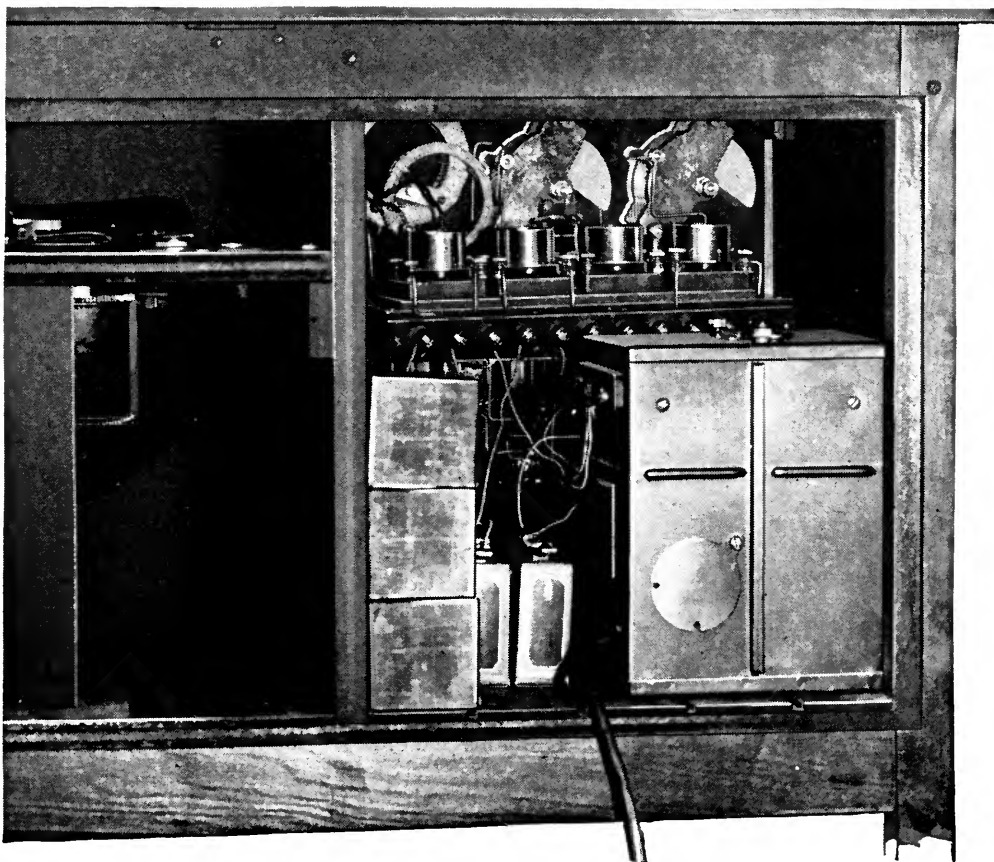

RADIO BROADCAST Photograph

USING RADIO BROADCAST'S PHONOGRAPH RECEIVER ON A. C.

In tests made in RADIO BROADCAST'S Laboratory it was found that the Balkite B could be used in connection with the Phonograph Receiver without causing any hum even though located in the same compartment as the receiver itself. The illustration shows the A, B, and C battery arrangement for use with dry battery tubes. Where standard tubes are employed it will be found that a small storage battery may be used in the same space without difficulty

More About Radio Broadcast's Phonograph Receiver

A Few Tips on Wiring, Circuit Juggling, and Operation Which
Should Be Found Useful for Home and Portable Models

BY ARTHUR H. LYNCH

ALTHOUGH we have called our latest receiver by a name which would indicate at first thought a somewhat limited use, the applications to which it may be put are many and the manner in which it performs has already made it the

most talked of receiver for home construction offered the radio public for many moons. We have not and do not expect to make any astounding claims for ease of assembly or performance. We do claim that RADIO BROADCAST'S Phonograph Receiver is the most prac-

tical application of a circuit which in itself is unusually good and that the receiver is still further one of the most practical receivers for operation by the whole family which has ever been devised.

Some of the interesting points of excellence of this receiver which are of more interest to the family than to the enthusiastic circuit fan are:

Exceptional tone quality. Operating the receiver on either two or four tubes produces real music and speech which makes it easy to recognize the voice characteristics of the speaker.

Satisfactory volume. On two tubes, local stations may be received on the loud speaker with enough volume to fill the average living room, and distant stations may be heard in a similar fashion at night. On four tubes the

volume may be made unusually great, and with a good loud speaker the music may easily be made loud enough to provide dance music for a large hall. One of the advantages of this receiver is that the loud music retains its tone because of the design of the tone amplifier circuit.

Ease of operation. When the plug is inserted in its receptacle, the current from the batteries is automatically turned on and only the actual number of tubes in use are lighted. When the plug is placed in the first receptacle, the receiver operates on two tubes; in the second receptacle, on four tubes. Whether two or four tubes are used, the finding of various stations and the control of their volume remains the same. Once the receiver has been set in operation and the preliminary adjustments made, it is but necessary to employ only two dials to choose the desired station and the dial settings usually coincide throughout most of the tuning range. Then, too, once a station has been logged it will be found again in the same place. The third, or volume control, need not be touched for ordinary operation but is put to work in building up the volume from distant stations when they would ordinarily be too weak. There is not a critical control in any one of the circuits, which means that the children may operate the receiver without any difficulty.

Selection of stations. This is one of the outstanding points of excellence in RADIO BROADCAST'S Phonograph Receiver, which has been recognized by the home builders and other interested persons as soon as they have seen one of the receivers in operation. Where with many other receivers it is difficult or impossible to prevent entertainment from one station to be separated from another, the difficulty may usually be overcome when our new receiver is put to work. It will show up very well in direct competition with the best of the superheterodynes, which are recognized as the standard by which selectivity, or the ability to separate the desired stations, is judged.

The cost of the parts for this receiver is not too low to cause any one to doubt its practicability. On the other hand, it is not too high to cause alarm to any one who is the owner of a cabinet or console type phonograph. Using high grade parts, to be sure of the best performance, will bring the cost (exclusive of accessories) to about fifty dollars. In what other way would it be possible for you and your family to get as much real enjoyment for anything like that figure?

Your phonograph will do very well to house

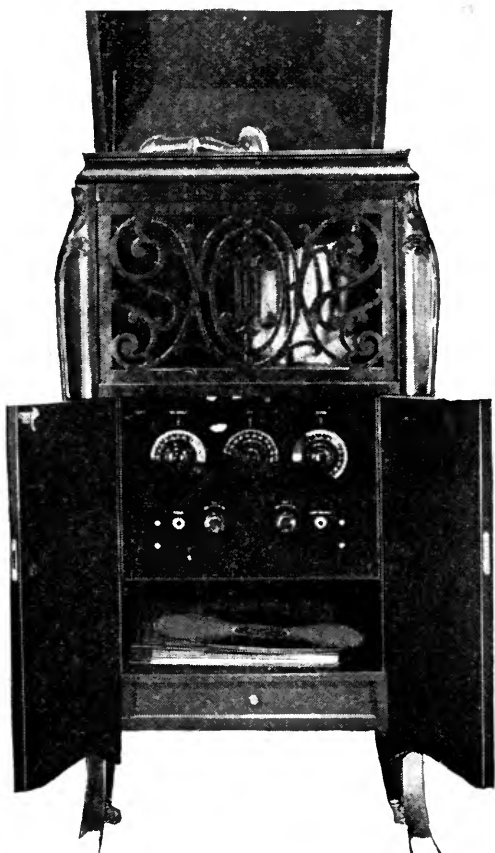

RADIO BROADCAST Photograph

A TYPICAL PHONOGRAPH

The panel used is somewhat larger than that required for an upright type Victrola. It will be observed that the layout of the equipment has not been changed in any way and that the assembly allows plenty of room for records. In a cabinet of this kind there is plenty of room for all of the batteries

this receiver, for it has been fitted into nearly every type of upright and console cabinet in our laboratory. In most of the phonographs we have used, there has been room for batteries of average size and since the receiver is economical in the drain on the batteries there is no reason for using batteries of more than average size. In fact, the drain is so small that the very small batteries, such as are used in portable receivers, may be employed with satisfaction. It is a simple matter to use the reproducing part of your phonograph with this receiver for a loud speaker and several combinations of this kind have been described in the two preceding articles which appeared in RADIO BROADCAST for June, and July. As the accompanying illustrations will show, there is plenty of space, even in the upright type of phonograph for filing your records, even after the receiver and its accessories have been installed. For the small apartment, a better combination would be very hard to find.

A FEW WORDS FOR THE CIRCUIT FAN

IN DESIGNING the receiver which has been described in the last three numbers of RADIO BROADCAST, we have attempted to keep in mind the needs of the class of folk who will derive most pleasure from the use of this receiver. It is not the last word in sensitive receivers, though it will out-distance any receiver we have seen with the sole exception of RADIO BROADCAST's Four-Tube Knockout Receiver and it compares very favorably with that. It is the kind of a receiver you can turn over to the family for their enjoyment, while you go ahead with your experimenting on another layout. Because of its compactness, some of the standard types of coils for use with the Roberts circuit can not be used and for your work on this circuit, if it is to be of an experimental nature, you may prefer the design described by John B. Brennan, our Technical Editor, in RADIO BROADCAST for September, 1924.

In connection with the phonograph receiver, as is also true of the Four-Tube Knockout, it is sometimes desirable to vary the plate voltage of the amplifying circuits, and we have found that it is possible to operate the reflex stage with but 45 volts on the plate circuit with some tubes, if the C voltage is reduced to 1.5 and the circuit is properly neutralized. It is rarely necessary to employ more than 22.5 volts on the detector plate, and we frequently use even less.

With some transformer combinations, we have found that an audio-frequency howl is



RADIO BROADCAST Phonograph

A PHONOGRAPH LOUD SPEAKER

By employing the Dulce-Tone made by the Teagle Company of Cleveland, Ohio in the manner indicated here, the tone chamber becomes the loud speaker horn and obviates the use of an outside speaker.

set up when all four tubes are used and the juggling of the plate and bias voltages described above usually does away with that difficulty. If it persists, it may be overcome by connecting the cores of the push-pull transformers together by a short piece of wire. It is not necessary, as a rule, to ground these cores, but it is sometimes found of advantage. Another trick which seems to work well in eliminating any trouble which may arise in the amplifier is the switching of the two grid leads to the input transformer in the push-pull stage.

Some of the adaptations of radio devices which are now on the market to RADIO BROADCAST's Phonograph Receiver are shown in some of the accompanying illustrations. Others will suggest themselves to the experienced home constructor, and we would greatly appreciate having them brought to our attention. We are attempting, with this receiver design, to produce the most satisfactory results possible for the greatest number of radio listeners, with the least difficulty. Every unit which can be incorporated in this design will make our plan just so much more effective, because it will make it easier to procure the necessary parts.

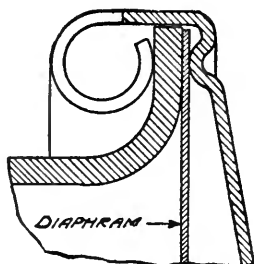

A NEW PHONOGRAPH UNIT

A very interesting loud speaker unit employing the special design illustrated here has been made by the Radioeve Company. This unit can be had in various impedances in order to match the output impedances of the tubes used. In tests made in RADIO BROADCAST'S Laboratory it has been found very satisfactory

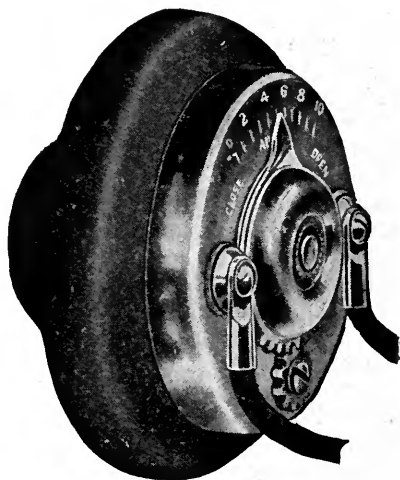

ADDITIONAL MODELS

THE two receivers, submitted to us by the Electrical Research Laboratories in Chicago, indicate very clearly how the devices made by that company, for other circuits, may be used in our receiver to good advantage. We recommend that receivers of this type be made with flexible wiring, however, and in our own work have found Acme Celatsite to work out very well. Number 18 bare, soft drawn copper wire does very well, when used with spaghetti.

The use of current tap devices, in the plate circuits has been tried and found very useful. Many of the tube type devices, such as the Mayolian, Mu-Rad, etc., have been used, but we have found that it is necessary to keep these devices some little distance from the receiver itself to prevent picking up the a. c. hum. Experiments with Balkite B show that it may be used right beside the receiver without causing any appreciable disturbance.

The new coils, which have been made by the F. W. Sickles Company for use in our phonograph receiver are shown on another page of this number, and we have found them to be very satisfactory. They may, of course, be used in any receiver, employing the now-

famous Roberts circuit. Another new set of coils has been produced by the Victor Radio Company, and they have been found to be very satisfactory. Other manufacturers assure us, that they are going to put coils for our phonograph receiver on the market and the temporary shortage, which is now apparent, should soon be overcome.

If we have been successful in presenting a design which will satisfy the demands of the average listener, the average home constructor, we will feel greatly encouraged and believe that we are serving our readers in a satisfactory manner. We constantly strive to increase the number of people who derive satisfaction from the operation of their receivers.

Next month, if it is possible to carry out the plans we are working on, we will illustrate a new group of phonographs in which our receiver has been installed and will illustrate new devices now manufactured for use in connection with it.

Where the space occupied in your phonograph by our receiver will not permit the use of the regular storage battery equipment, it is possible to use dry-cell tubes and the very small type B batteries and flashlight batteries in the grid circuits for biasing.

Additional photographs showing other applications of the Phonograph Receiver to various panels and equipment are found on the two following pages

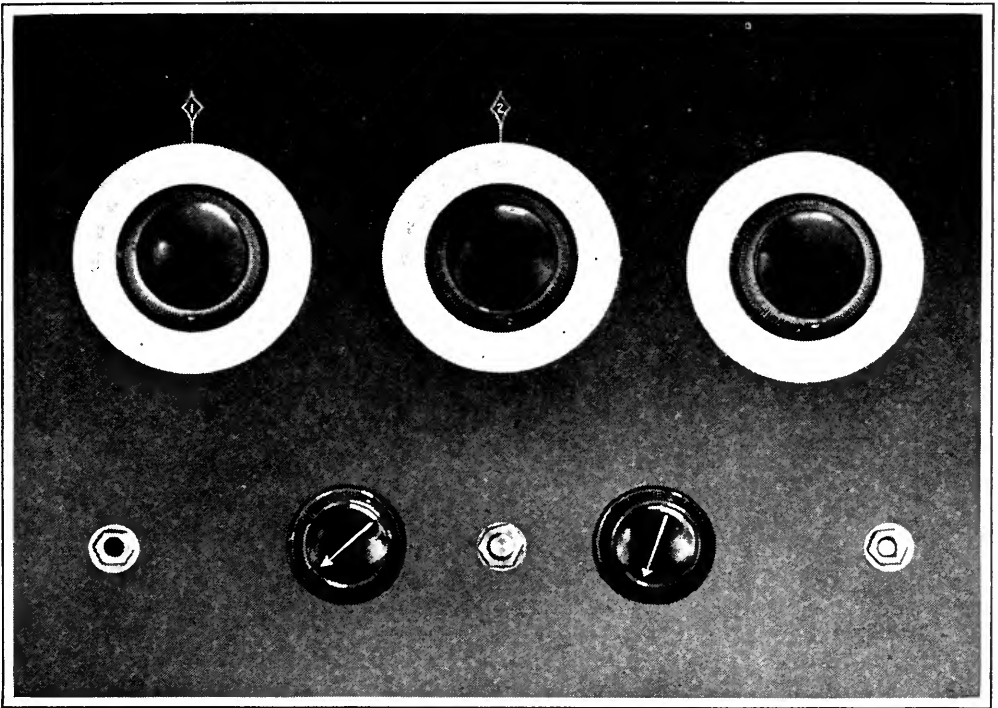

RADIO BROADCAST Photograph

RADIO BROADCAST'S PHONOGRAPH RECEIVER IS UNIVERSAL

This receiver composed entirely of parts made by the Electrical Research Laboratories in Chicago illustrates in a very comprehensive way the ease with which products of different design may be applied to our Phonograph Receiver. Some slight changes in wiring may be necessary and in this case the most significant one is the wiring of the transformers which is done above the sub-panel instead of below it after the manner illustrated in our past articles

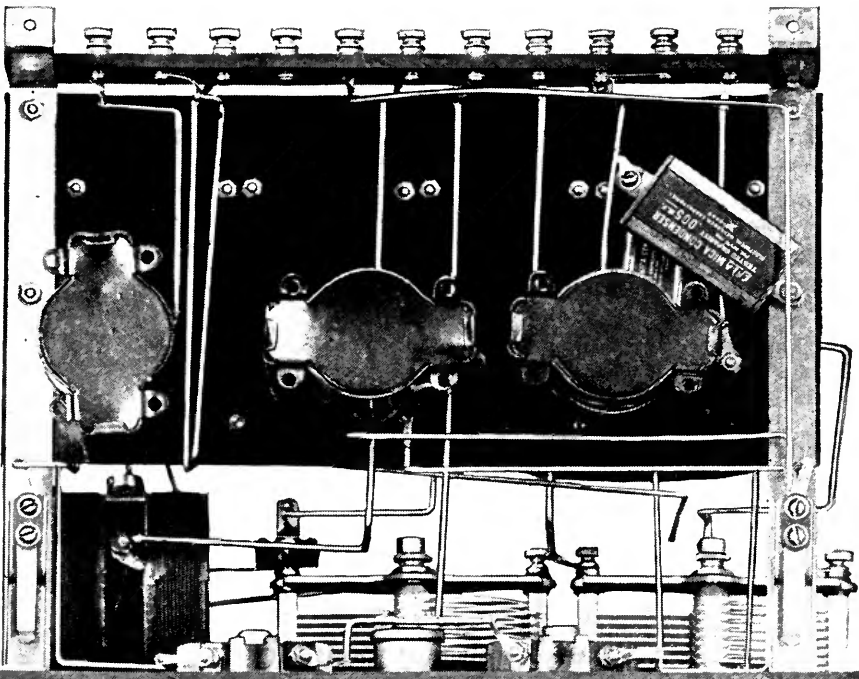

RADIO BROADCAST Photograph

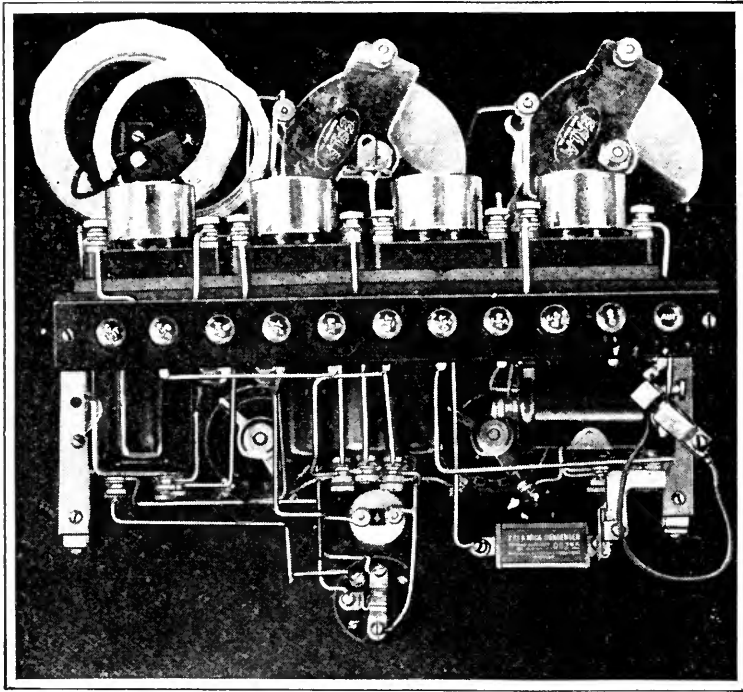

RADIO BROADCAST Photograph

THE ONLY DIFFERENCE

Between the two receivers illustrated here is found in the antenna circuit. In the upper receiver a Selectoformer has been used whereas in the lower receiver one of the Toroid coils made by the Electrical Research Laboratories in Chicago has been incorporated in the circuit. In building receivers of this kind it is much better for the home constructor to fuse flexible wiring instead of the bus bar illustrated here

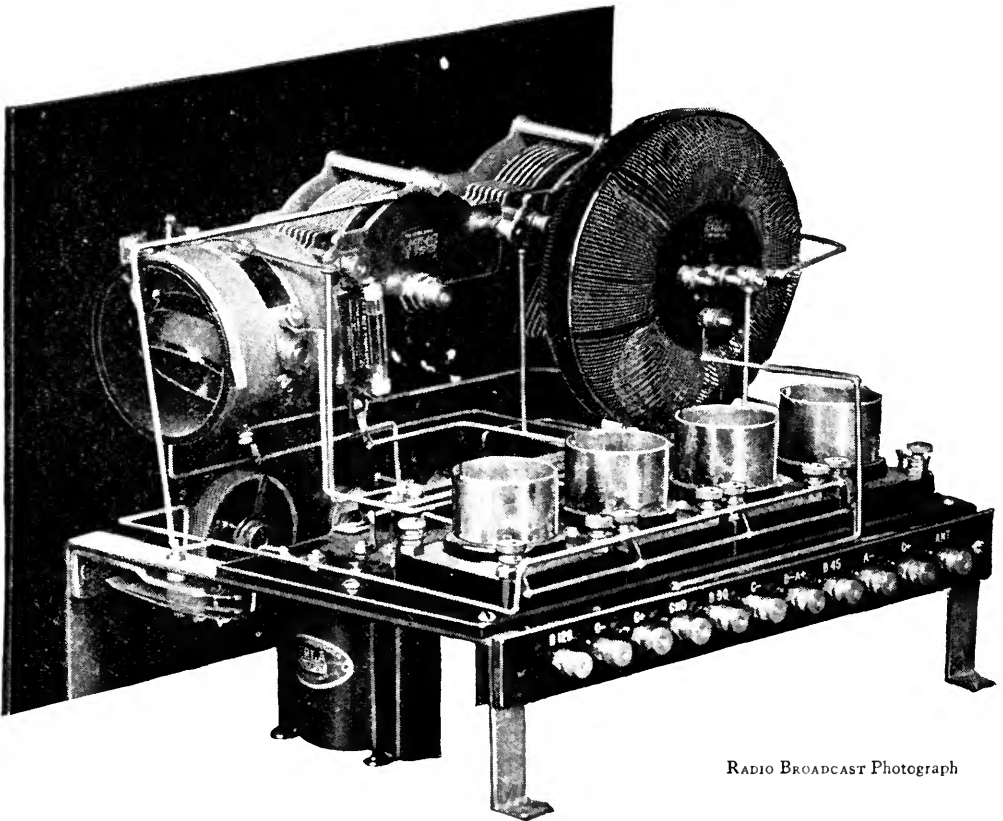

RADIO BROADCAST Photograph

"NOW, I HAVE FOUND . . ."

A Department Where Readers Can Exchange Ideas and Suggestions of Value to the Radio Constructor and Operator

NEUTRALIZING THE ROBERTS KNOCKOUT

PROBABLY the most satisfactory way to neutralize a tuned radio frequency amplifier is to use the method recommended by the neutrodyne manufacturers. This method may be applied to the Roberts with good results and eliminates the uncertainty of whether or not the amplifier is really neutralized or not.

A glance at the diagram, Fig. 1, shows that the Roberts consists of three circuits, tuned radio frequency, detector with regeneration, and the reflex circuit. It is because of the reflex circuit that ordinarily the regular method of neutralizing cannot be used, because in removing the first tube, the audio frequency circuit is broken.

However, if the reflex circuit is eliminated, we still have one stage of tuned radio frequency and detector with regeneration and can then proceed to neutralize in the regular manner, as in any other tuned radio frequency amplifier.

The procedure is as follows—remove the phones from their regular position in the plate circuit of the first tube in the circuit (X) and place them in the plate circuit of the detector tube (Y). We then have a set consisting of one stage of tuned radio frequency amplification, and a detector with regeneration.

In the two-tube set, when the experimenter removes the phones from X, it leaves the plate circuit of the first tube open. This may be remedied by short-circuiting a phone plug and inserting it in the jack or short circuiting the phone binding posts, as the case may be.

With the three-and four-tube sets this is not necessary as the jacks will take care of this.

Tune-in on a semi-distant station to maximum signal strength.

Then remove the first tube and insulate one of the filament prongs with a slip of paper or spaghetti and replace the tube in the socket. Return to bring the signal to loudest point and then adjust the neutralizing condenser until the signal vanishes or reaches minimum strength. Remove the insulation from first tube, replace phones to their regular position, and as Roxy so ably puts it, "There you are."

—M. B. WHITNEY, Bethel, Vermont.

A SIMPLE AND EFFICIENT FORM FOR WINDING YOUR OWN COILS

IF YOU are interested in the Roberts Circuit here is an arrangement that will prove to be of a definite value to you in winding the necessary coils. A small block of hard wood (maple perhaps), is turned to a cylindrical form of $2\frac{1}{2}$ inches in diameter and $2\frac{1}{2}$ inches in length, as in Fig. 2. The circumference of this form is divided into thirteen equal parts. The easiest way to accomplish this is to lay out the circle on a sheet of paper, as in the diagram and make several trials at

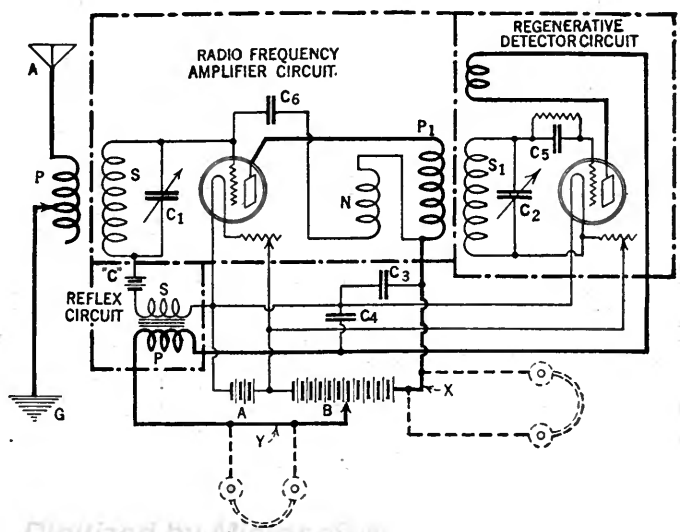

FIG. 1

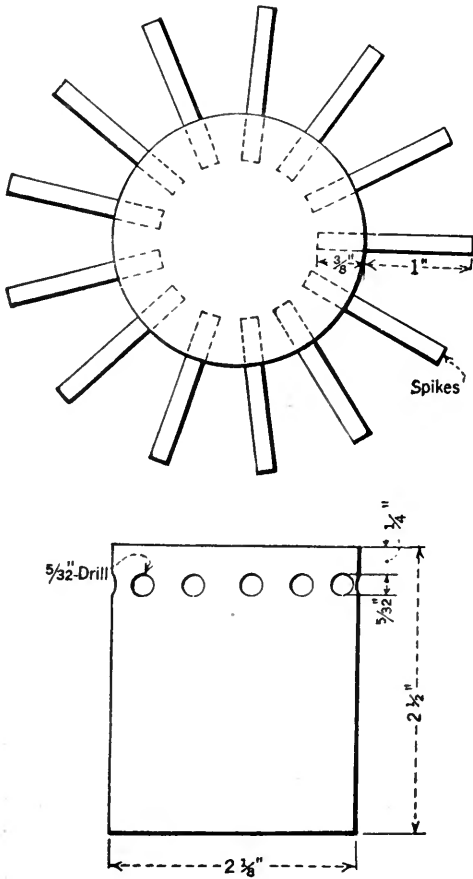

FIG. 2

division, and then when the result is satisfactory, transfer it to the cylinder.

In drilling the holes, care must be taken to keep them of the same depth on the centers. The pins are made from 4- or 5-inch nails. After the heads and points have been removed they should be cut approximately $2\frac{3}{4}$ inches in length, then cut in half.

Thirteen of these pins must be prepared. They should be rubbed with emery cloth until a fairly snug fit in the cylinder is produced. After the coil is wound, a small dab of collodion is applied to each intersection. The coil is quite easily removed by first twisting and then pulling out each pin with a pair of pliers.

And now for the coils. Antenna coil P consists of 40 turns with taps of 3-5-7-10-40. Coil S has 44 turns. All coils except the NP one are wound over two pins and then under two pins and so on with No. 22 d.c.c. wire. Coil NP consists of two wires of No. 26 d.c.c. wound together, over and under each pin twenty times. Try twisting these two wires

together before winding. The tickler coil T consists of 18 turns of No. 22 d.c.c. wire.—RALPH PALMER, London, Ontario, Canada.

R. F. TRANSFORMERS AND HIGH PLATE VOLTAGE

IN WINDING radio-frequency transformers for an amplifier as described in the May RADIO BROADCAST it is common practice to place the "S" winding directly on top of the P and N windings. As the difference in d. c. potential between the "S" winding and either the P or N winding is generally in the order of 90 volts or more, the ordinary cotton covering of magnet wire is not to be depended upon. When this insulation between these windings breaks down, the result depends largely upon the condition of the B supply (mine is 140 volts of large size storage and the results were surprisingly complete). Just to play safe, in winding the coils put six or eight turns of heavy silk fishing line or other cord between the S winding and the P and N windings.

After having done this, the next and equally essential spot in which to place a safeguard is the neutralizing condenser circuit. I used the commercial type midget variables. These were none too well built and one of them shorted while being adjusted. Fortunately this short occurred on the proper side of the A battery and the tubes survived, but one of the r.f. transformers disappeared in a nice puff of green smoke. To avoid a recurrence of these pyrotechnics, I have put a .001 mfd. fixed mica condenser in series with the leads between the N coil and the variable neutralizing condensers. These condensers are sufficiently large in capacity so as to have little effect upon the settings of the neutralizing condensers with which they are in series and the protection which they afford well justifies their cost.—M. K. T.

HELPS FOR CONSTRUCTORS

TO START a screw in an inaccessible place, rub some beeswax into the slot, push the point of the screw driver into the slot and place it where desired.

To recover a screw or other small part which has been dropped into an inaccessible place, put some beeswax on the end of a stick or suitably shaped tool, push it against the screw and remove it.

Never put a hot soldering iron into the can of acid soldering paste. It ruins the paste and the solder will not flow as easily or adhere as firmly as before. Even melting it down

from the sides of the can injures it. Acid soldering paste has no place in radio work anyway. Rosin core solder is just as easy to use if the surfaces are clean and the end of the solder is held against the metal in such a position that the melted rosin flows freely over the metal before the melted solder flows over it. Of course, the point of the iron must be clean and tinned to solder well with any kind of flux, and as the solder on the point becomes dirty from oxidation it should be wiped off. Solder will not adhere firmly unless the surface of the metal has been raised to a temperature high enough to melt the solder.—JOHN V. FREDERICK, Los Angeles, California.

WINDING COILS "ON AIR"

A GOOD form on which to wind the efficient "pickle bottle" coils, is made from a piece of bakelite tubing of the required diameter, which has a slot about $\frac{1}{8}$ inch wide cut through it lengthwise. The tube is then placed in a winding rig, the proper number of turns of wire put on and secured by narrow strips of gummed paper, or otherwise. After which the tube may be taken from the rig and the edges sprung together sufficiently to allow the coil of wire to drop off. The coil may then be further strengthened by putting narrow strips of gummed paper inside.

A SAFE HOMEMADE B SUBSTITUTE USING 110 VOLTS A.C.

THIS B battery substitute uses one toy transformer such as is sold for small electric trains, etc., and while it has been suggested before, this circuit was always considered unsafe, due to the fact that generally one leg of the alternating current line in household use is grounded. You can test this by putting a 110-volt light globe in a circuit in series with either of the 110-volt wires and a ground connection. If the globe lights up then that wire is not grounded, if it does not light, the wire touched is grounded.

In the case of the radio circuit the minus B is practically always grounded. In the case of this B substitute, we must have the same wire grounded, otherwise there will be a direct short and something will happen. Where the B transformer is set

in a stationary place and permanently wired in to the 110-volt circuit the grounded side can be determined and the connections made accordingly. But where it is desired to merely screw a plug into any light socket for the B current the hook-up shown in Fig. 3 must be used. First a two-part screw plug should be used. Second a 110-volt light globe must be wired into the circuit as shown.

With the B substitute connected to the set and the ground (and it makes no difference whether the ground runs from the negative B on the set or from the B substitute unit,) screw the first half of the plug into the socket. Place the other half in place and if the bulb does not light the grounded wire is in circuit with the grounded negative B. This is O. K. However if it does light it indicates that the non-grounded side of the line is in circuit with the grounded negative B. This we do not want.

To correct matters, reverse the plug connection, by pulling it out and turning half around and insert. The bulb does not light in this position. The connections are now safe for operation of the radio set. This light globe also acts to prevent burning out of the tubes in case of a short circuit in the set.

The writer has used a B substitute on a three-tube set with 201A tubes and also on a 8-tube super-heterodyne using UV-199 tubes and has had excellent results.

A toy transformer of 75 watts capacity is used. For the choke a small bell-ringing transformer is used and two condensers of 3 mfd. each. An adjustable wire resistance controls the 201A tube used as a rectifier and I find it delivers ample current for the sets mentioned above.

The voltage delivered will range from 90 to 105. The proper voltage for the detector current can be obtained by inserting a resistance in the positive B line after taking off a tap for the amplifier voltage, which generally should be 90 volts. This B supply

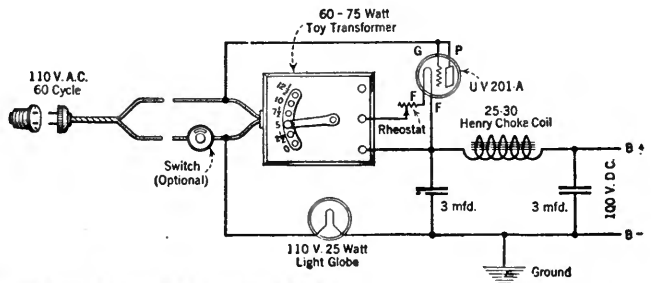

FIG. 3

substitute can be built for a cost not exceeding \$12.50.

Alternating current hum will in no case be noticeable using the loud speaker. In the case of headphones, the a.c. hum is noticed when forcing the set on DX but not ordinarily. More condensers and chokes will eliminate the balance of the a.c. hum.—JAMES B. HAYS, Boise, Idaho.

RHEOSTATS AND VERNIERS CONTROLLED WITH HORIZONTAL DIALS

THE experimenter who wishes to incorporate a refinement and a novel mode of adjustment in his receiver may follow the suggestions in the drawings, Fig. 4.

The rheostat may be mounted under the socket in a horizontal position with the bracket, shelf, bushings and bolts. The dial used is cut from a piece of bakelite and the edge serrated with a file. It must be large enough to extend $\frac{1}{2}$ inch through the panel perforation.

The extra contacts of a vernier condenser, in which a low value (3 plate) unit is incor-

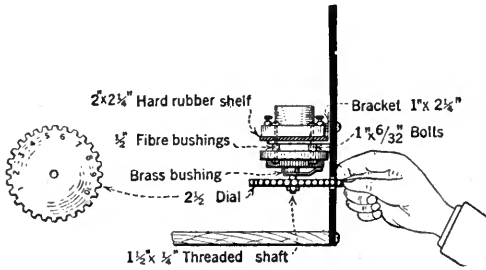

FIG. 4

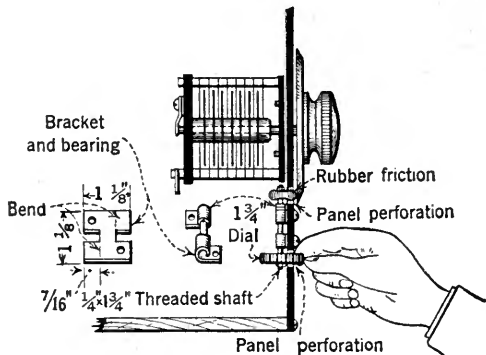

FIG. 5

porated, theoretically increase its internal resistance. Any condenser, variometer, or coupler dial may be fitted with a friction vernier as shown in Fig. 5.

The panel is perforated below and behind the dial and the vertical shaft is held in position by the bracket bearing which is cut and bent from heavy brass or copper. The shaft is fitted with a rubber knob at the top (the rubber may be part of an old shoe heel) which working through the aperture comes into frictional contact with the back of the dial. The dial at the other end of the shaft extends through the panel.

These dials may be turned with a sidewise rubbing movement which will give true micrometer adjustment.—J. T. GARVES, Huntington, Tennessee.

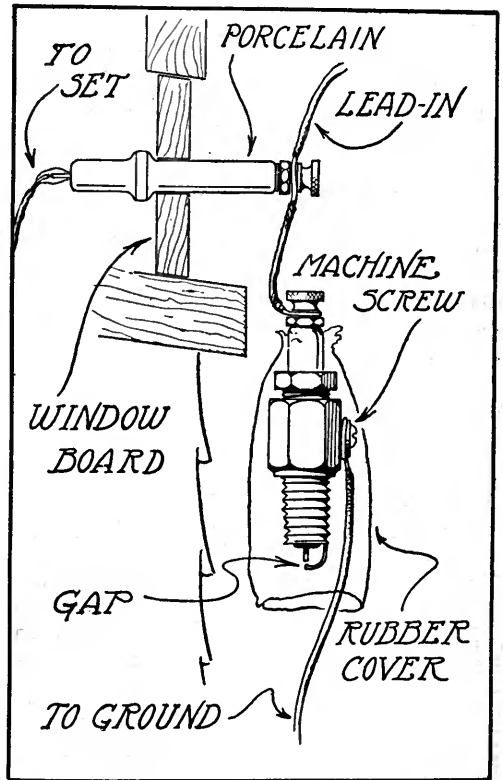

FIG. 6

RADIO LIGHTNING ARRESTER MADE FROM SPARK PLUG

A GOOD, serviceable lightning arrester that will give ample protection from lightning surges to the set can be made by any radio fan from old spark-plugs. All that is necessary to insure safety, is to see that the porcelain and shell are in good shape so that there are no leakages of antenna current to affect the reception qualities of the receiver.

The illustration, Fig. 6 shows the method of installation and is explained as follows.

Drill and tap a small hole in the shell as shown, and thread in a short machine screw with washer. Lead the antenna down to the terminal of a spark-plug porcelain thrust through a window board. The lead to the set can be soldered to the contact wire in the other end of the porcelain as indicated. That takes care of the connection of antenna to set and insures good insulation from the house.

Now hang the spark-plug previously mentioned from the binding post of the above mentioned porcelain by a short piece of wire. Then connect the ground wire to the shell by the machine screw and the arrester is complete. By tying a short length of old inner tube around the plug, rain will be prevented from short-circuiting the gap between the points of the plug. It is this gap that allows a surge of electricity from the antenna to pass down into the ground wire rather than allow it to pass through the set. It is the same idea as employed in many forms of commercial arresters and will do the work as well and at less expense. A separate ground wire will be necessary from the set to the ground connection.—L. B. ROBBINS, Harwich, Massachusetts.

MAKING HARD RUBBER SPIDERWEBS FOR THE ROBERTS SET

WITH the aid of the pattern published in RADIO BROADCAST for January, 1925, cut a template from cardboard. Cut five 5 inch squares from $\frac{1}{8}$ inch hard rubber. Drill each square at its center to pass a $\frac{5}{16}$ machine screw, and snip the corners off so as to approximate a circle.

Make a jig from two pieces of hard wood about $10'' \times 3'' \times \frac{3}{4}''$. The construction is shown in the sketch. Clamp the two pieces together, and drill three No. 28 holes, one $2\frac{3}{8}$ inches from the top, the second $3\frac{1}{2}$ inches below that, and the third an inch from the bottom. Remove the pieces from the vise and clamp them

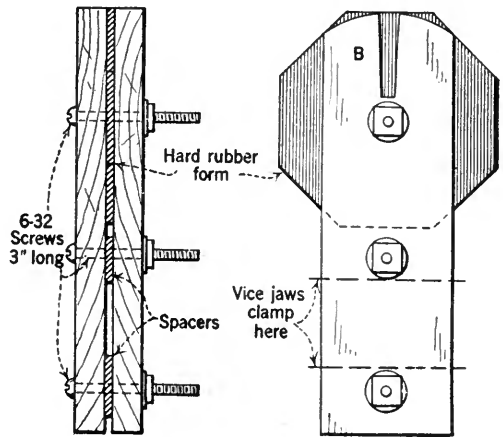

FIG. 7

together with $\frac{5}{16}$ machine screws 3 inches long. Place the cardboard template underneath the head of the top screw; mark and cut the slot and top as shown.

Using the cardboard template, scratch the outline on the first rough form and clamp it between the two halves of the jig. Spacers are used to keep the halves of the jig parallel. Clamp the jig in a vise; line up the scratches of one slot and apply a clamp at B to keep the form from turning. Make two cuts with a hack saw. Knock off the waste material with a hammer and screw-driver. If the cut is stopped short of the bottom, the piece will break off above the danger point. Use a file to finish the slot and round the top. Loosen the clamp, turn the form to the next set of scratches, tighten the clamp, saw, chip, file, and continue the exercise until the form is finished. The jig and form is shown in Fig. 7.

If this first form is satisfactory, use it as a template to scratch another, as the cardboard form is probably *hors de combat* by this time. Then clamp the remaining four in the jig, the marked form being nearest you; and, if you keep everything lined up, you will have a good set of forms in short order.—WAYLAND S. BAILEY, Cambridge, Mass.

THE "Now I Have Found . . ." department in this magazine is planned to furnish an outlet for the many excellent ideas dealing with various features of radio construction and operation which reach our office. If you have an idea about a valuable and useful new circuit, some new device or a construction or operating suggestion, we should like to have it. We do not want simple or obvious suggestions, and material to be acceptable for this department must offer something of definite value to the constructor; mere novelty is not desired. Payment from two to ten dollars will be made for every idea accepted. Manuscript should not be longer than 300 words and typewritten. An award of twenty-five dollars will be paid for the best article published in every three-month's period.

Address your manuscript to this department, RADIO BROADCAST, Garden City, New York.



See the Announcement on Page 548

QUERIES ANSWERED

I WISH YOU WOULD RE-DESCRIBE THE WINDING OF THE COILS USED IN THE ROBERTS RECEIVER.
H. S.—Minneapolis, Minnesota.

HOW DO YOU APPLY THE ROBERTS NEUTRALIZATION TO THE NEUTRODYNE CIRCUIT?
B. O.—Coffeyville, Kansas.

SHOULD A RHEOSTAT BE PLACED IN THE POSITIVE OR NEGATIVE SIDE OF THE FILAMENT SUPPLY?
A. F.—Baltimore, Maryland.

WHAT PRECAUTION DO YOU ADVISE IN CHARGING B BATTERIES FROM 110-VOLT A. C. LINES?
H. W.—New York City.

WHY, IN THE HANSCOM "SUPER", DOES THE RECEIVER NOT OSCILLATE ON THE LOWER WAVES?
C. J. B.—Dover, Delaware.

WILL YOU PUBLISH A CIRCUIT OF AN EFFICIENT TRANSMITTER-RECEIVER?
J. A. H.—Augusta, Maine.

WILL YOU OUTLINE A SYSTEM FOR A COMMON AND STANDARD PRACTICE OF CONNECTING TOGETHER A AND B BATTERIES?
H. E.—Lincoln, Nebraska.

I WANT TO LEARN THE CODE. CAN YOU TELL ME A SATISFACTORY METHOD?
G. J.—Boston, Massachusetts.

HOW TO MAKE THE ORIGINAL ROBERTS COILS

MOST of the recent descriptions of receivers employing the Roberts system of neutralization have referred to the coil units as designed by Mr. W. Van B. Roberts and described by him in the April, 1924, RADIO BROADCAST.

Slight modifications were made in the design as described in the May, 1924, magazine which are now standard.

To make these coils, the constructor must have five spiderweb forms $2\frac{1}{8}$ inches inside diameter with

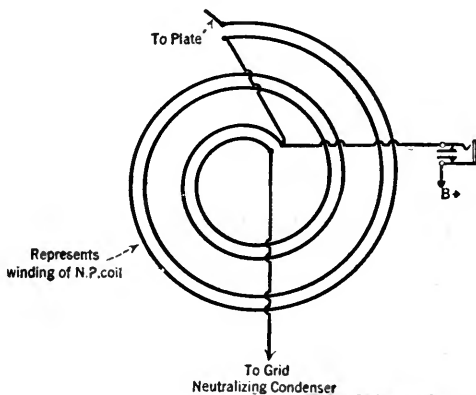

FIG. 1

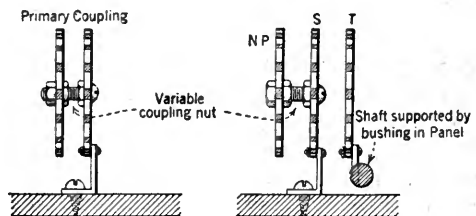

FIG. 2

spokes $1\frac{7}{8}$ inches long, $\frac{9}{16}$ inches wide at the top and $\frac{5}{16}$ inches wide at the inside diameter.

The antenna coil is wound with forty turns of No. 22 d. c. c. wire and tapped at the 1-2-5-10-20-30 and 40th turns. The secondaries are wound each having forty-four turns of the same wire. The tickler is wound with twenty turns. The N-P coil consists of a pair of No. 26 d. c. c. wires, wound together for twenty turns. In these coils, the beginning of one and the end of the other are connected together and from this point a lead is brought to the top blade of the double circuit jack in the receiver.

The remaining leads of this coil connect, one to the plate and the other to the grid neutralizing condenser. See Fig. 1. The antenna, secondary, and tickler coils are wound over two and under two spokes. The N-P coil is wound under one and over one spoke of the coil form.

A mounting scheme is suggested in Fig. 2.



The Morning Offering
will now be taken -

You may escape the collection ~ but not the need of **OZARKA SERVICE**

THE satisfaction you receive from your radio depends not on what it does once in a while—but night after night and month after month. Whether you grin or cuss depends on the service behind your radio.

Ozarka radio instruments are *only* sold by trained factory representatives, men who not only specialize in radio but sell and service Ozarkas only. 3,100 of these men, trained directly under Ozarka engineers constitute a service force, unequalled elsewhere in radio today.

When you buy a radio you'll compare appearance, tone, volume and selectivity by having various instruments set up in your own home

but—that isn't enough—compare the service behind each one.

Any Ozarka factory representative will set up an Ozarka in your home—he will not even operate it himself, but will depend for his sale on what you yourself do. If you, by your own operating, do not bring in the distance, the volume and tone, you expect a radio to give, then you do not buy the Ozarka. If you do buy it, you can rest assured, no matter what happens, a competent service man is at your call at all times. No Ozarka representative can sell Ozarka Instruments without giving Ozarka service. You are entitled to such service—demand it!

That is why our book, "Ozarka Instruments No. 200," describing all models of Ozarka should be of particular interest to you. This book and the name of the Ozarka representative near you, will be sent immediately at your request. Please give name of your county.

We Have Openings for More Ozarka Factory Representatives

OZARKA Incorporated, is now entering its 4th year. From a beginning with one engineer, one stenographer, one salesman—our present president, the Ozarka organization has grown to over 3100 people. There must be some good reason for this growth.

Ozarka instruments have made good—they have more than met competition. Ozarka representatives have made good not only because Ozarka instruments were right, but because they have been willing to learn what Ozarka engineers were willing and capable to teach them—Ozarka unusual salesmanship and Ozarka service.

Radio offers a wonderful opportunity to men who are willing to start at the bottom and build. You need not know salesmanship, but will you learn what we will gladly teach you? You may not know radio, but we can and will teach you if you will do your part. With such knowledge and willingness to work, it doesn't seem possible that you cannot make good. Sign the coupon below, don't fail to give the name of your county. Better still write a letter, tell us about yourself and attach coupon. If interested in our salesman's plan ask for "Ozarka Plan No. 100."

OZARKA

119 Austin and La Salle Streets
Chicago, Illinois



INCORPORATED

119 Austin and La Salle Streets
Chicago, Illinois

Gentlemen: Without obligation send book "Ozarka Instruments No. 200" and name of Ozarka representative.

Name.....
Address..... City.....
County..... State.....

YOU'LL KNOW THE MAN BY THIS BUTTON!

Gentlemen: I am greatly interested in the FREE BOOK "The Ozarka Plan" whereby I can sell your radio Instruments.

Name.....
Address..... City.....
County..... State.....

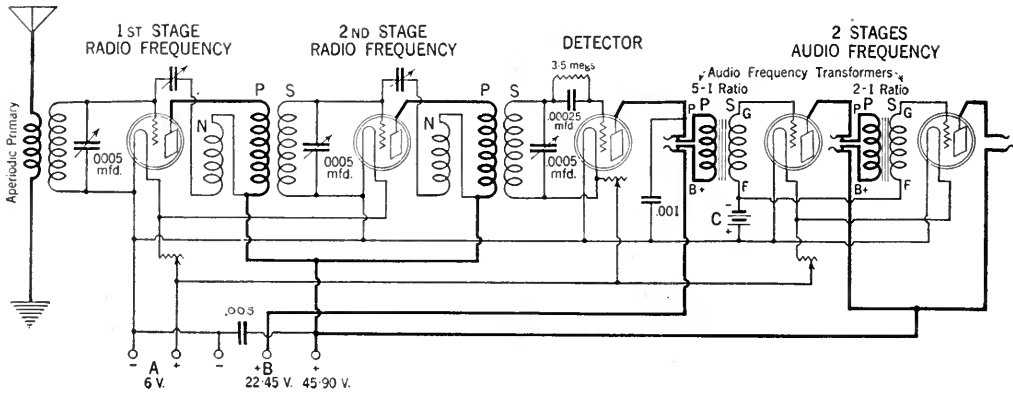

FIG. 3

AN R. F. CIRCUIT EMPLOYING ROBERTS NEUTRALIZATION

FOR a two-stage radio-frequency amplifier, with detector and two stages of audio-frequency amplification, the circuit in Fig. 3 is recommended.

The Roberts system of neutralization is employed and is recommended over the other forms of neutralization. In others, the maximum voltage gain is not realized, because the primaries of the usual couplers are wound with only six to ten turns of wire. In the Roberts system, more gain is obtained by the use of primaries of 20 turns. These primaries are double wound and connected as shown in the circuit diagram. No regeneration is employed but will increase the efficiency of the receiver when included.

It may also be found that two stages of straight audio frequency amplification will distort the signals received on account of not being able to handle the detector output properly. When this is the experience, push-pull or resistance-coupled amplification will usually prove satisfactory.

RHEOSTAT LOCATION

THE placement of a rheostat in either the negative or positive side of the vacuum tube filament supply opens up a question which is subject to much discussion. It is our purpose here simply to make some observations which may aid the experimenter in his constructional work.

In a detector circuit it is desirable to have the return side of the secondary coil connect to the positive filament lead so that a positive voltage be applied to the grid of the tube. This is quite necessary for rectification purposes.

Now in an amplifier circuit, it is desired to have the return side of the secondary of the audio transformer connect to the negative side of the filament lead so that the amplifying action will take place, figuratively speaking, on the straight portion on the vacuum tube characteristic curve.

By placing a rheostat in the negative line, a varying negative potential of from 0 to 6 volts may be obtained, providing the return side of the audio

transformer secondary connects to a point on the rheostat winding. The value of this negative potential will depend upon the location of this connection on the rheostat winding.

Naturally if a C battery is used there is no need for obtaining a negative grid bias in this manner.

It is debatable whether or not any difference in operation can be noticed when comparisons are made with the rheostat first in one side and then in the other side of the filament leads where the return is made direct to the negative filament socket terminal.

In the December, 1924, Grid on page 304, Fig. 1, is shown the use of a C battery and potentiometer to give a smoothly varying value of negative grid volts. Of course such a circuit is practical for test and research purposes but not for ordinary continuous use. The shunting of a 400 ohm potentiometer across a $4\frac{1}{2}$ -volt C battery would discharge the battery at the rate of .011 amperes until it was completely run down.

HOW TO CHARGE B BATTERIES FROM A. C.

THE charging of storage B batteries presents a problem to the individual, especially where the house current is alternating.

Several months ago explicit instructions with diagrams were contained in the Grid showing the charging of B batteries from various d.c. line supplies.

This discussion will take up the charging of B batteries from a. c.

Usually, in a radio installation, about 96 to 124 volts of B battery are used. Now ordinary alternating current lines fluctuate in the voltage supply varying approximately from 106 to 115 volts for a 110 volt line. Generally the drop occurs at night when the lines are heavily loaded for illumination purposes.

Therefore, to be on the safe side it is well never to try to charge more than 96 volts (2 units of 24 volts in series) at a time. Because if the line voltage drops below that of the batteries they will discharge back into the line. Of course several banks of 96 volts each may be connected in parallel but the load on the line will be greater.

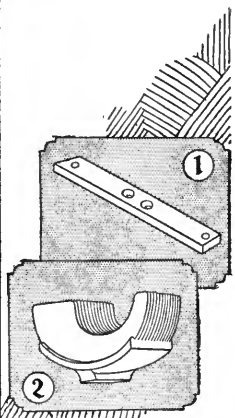
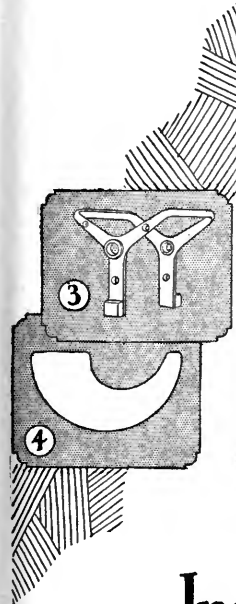
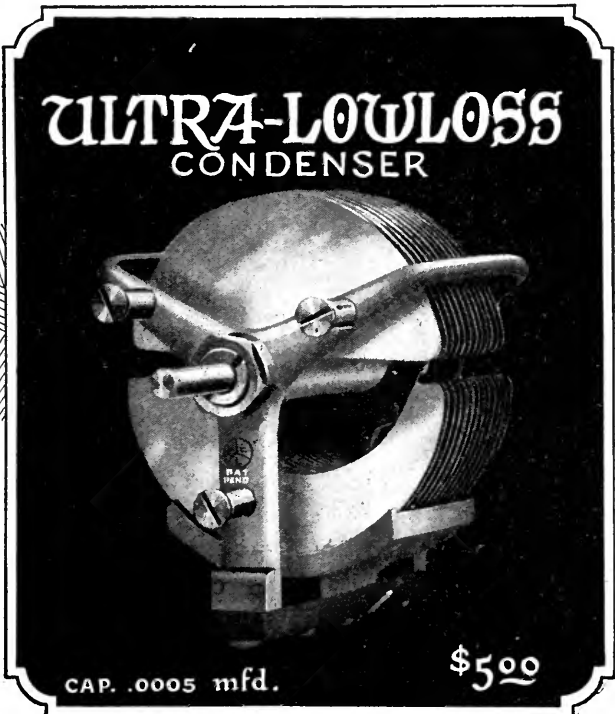

Unusual Features Increase Receiving Efficiency

IN LESS than six months the Ultra-Lowloss Condenser has proved its right to leadership by greatly simplified design, greater tuning efficiency, and radically different operating results—not only in the eyes of scientific and engineering men, but with the buying public as well.

These are the predominating Ultra-Lowloss features: (1) Single insulation strip reduces leakage losses materially, (2) Monoblock mounting with plates cast into block reduces series resistance and assures positive contact, (3) Minimum of metal of high resistance material in the field and frame reduces eddy current losses, (4) Cutlass Stator Plates produce a straight line wavelength curve—separating stations evenly over the dial. Each degree on a 100 degree scale dial represents approximately 3½ meters over the broadcast wave length range.

This even separation applies to both high and low wavelengths! Simplifies tuning materially!

The Ultra-Lowloss Condenser is a recent development of R. E. Lacault, E. E., originator of the famous Ultradyne receiver.

Design of Lowloss Coils furnished free with each Condenser for amateur and broadcast wavelengths showing which will function most efficiently with the Condenser.

At your Dealer's. Otherwise, send purchase price and you will be supplied postpaid.



R. E. Lacault

To manufacturers who wish to improve their sets

I will gladly consult with any manufacturer regarding the application of this condenser to his circuit for obtaining best possible efficiency.

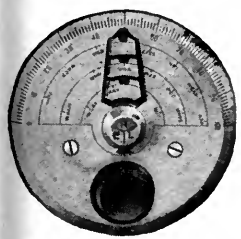

Simplifies radio tuning. Pencil record a station on the dial—thereafter, simply turn the finder to your pencil mark to get that station instantly. Easy—quick to mount. Eliminates fumbling, guessing. Furnished clockwise or anti-clockwise in gold or silver finish. Gear ratio 20 to 1.

Silver \$2.50.
In gold finish, \$3.50.

ULTRA-LOWLOSS CONDENSER

Write for Descriptive Folder.



PHENIX RADIO CORPORATION :: 116 C East 25th Street :: New York

The charging device may be any one of several types such as the chemical rectifier, vibrating magnetic rectifier or tungar tube rectifier.

In the first named, the drop through the charger is about 30 volts so some means for stepping up the voltage must be employed. Transformers are on the market which will accomplish this.

The rate of charge depends upon the resistance of the circuit and voltage of the supply. The battery resistance is negligible so therefore some external resistance must be employed.

Vibrating rectifiers depend upon mechanically perfect construction and adjustment for satisfactory operation and will not be discussed here.

In the tungar rectifier, the tungar tube by an electronic rectifying action produces the desired effects.

As there is a voltage drop through this tube the same means for stepping up the voltage as used for the chemical rectifier must be employed.

For circuit diagrams relative to the various points brought out herein the reader is referred to pages 230 to 236 of the July, 1924, RADIO BROADCAST.

WHY THE HANSCOM "SUPER" WON'T OSCILLATE ON LOW WAVES

IN THE usual radio circuits, experimenters have noted that on tuning to the lower broadcast waves, the tendency of the receiver to go into oscillation increases conversely with reduction in wavelength. In the Hanscom super-heterodyne, just the opposite phenomena has been experienced.

Mr. Hanscom explains as follows:—

In regard to the tendency to oscillate on the higher waves, this is really a tuned plate effect of the first tube, the resonant point in the plate circuit being governed by the inductance of the Duratran transformer. We think that some of this difficulty may be due to long leads to the neutralizing condenser as it is customary for the set to oscillate at about 400 meters with the Chelton condenser set at zero. In general, the more turns on the loop the earlier the set will oscillate. In order to prove the case we suggest disconnecting the lead from the Duratran to the Chelton condenser after tuning in a low wavelength station, and it will be found that the signal strength materially increases. Unfortunately there is no small condenser on the market with a sufficiently low minimum capacity although we have had good success with a condenser employing three regular size plates which were cut away so that the rotor and stator plates were a considerable distance apart at zero setting.

The foregoing is an explanation of the broadness of loop tuning because the loop tuning becomes sharper as the oscillating point of the first tube is approached.

A TRANSMITTER-RECEIVER CIRCUIT

HEREWITH is described a transmitter-receiver circuit which of late has been in demand, especially by our English readers. The description of this apparatus originally appeared in the May 1923 RADIO BROADCAST.

The circuit comprises the usual one-tube arrangement with the exception that by means of a special keying system it also acts as a transmitter. It is

especially desirable as a portable affair. Its only drawback lies in the maintenance of a fixed transmitting adjustment and at the same time allowing of tuning for receiving. Ordinarily transmission occurs at only one of two or possibly three pre-arranged wavelengths. The tuning and adjustment to resonance at these wavelengths is reasonably sharp so that to maintain two-way communication it would be necessary to shift wavelength adjustments, supposing that the two stations were not working on the same wavelength. As an example, if one station (A) works on 150 meters and the other (B) on 180 meters then A after concluding his transmission must shift his dials so as to listen in on

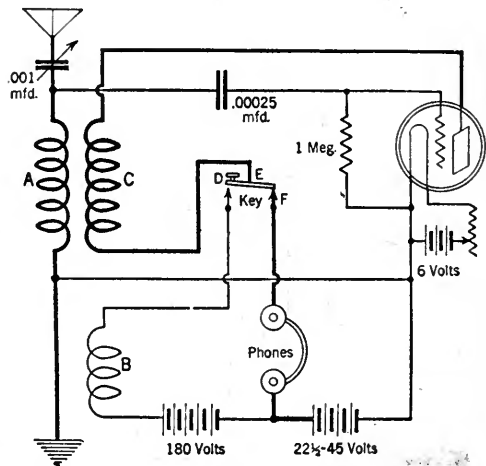

FIG. 4

180 meters (B's wave). Of course, this is not a serious disadvantage, but unless there is means for accurately retuning the set for transmission every time communication is maintained it makes it

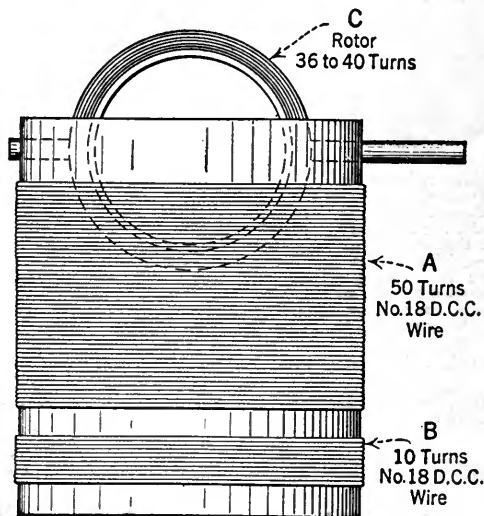

FIG. 5

EVEREADY HOUR
EVERY TUESDAY
AT 8 P. M.

Eastern Standard Time
For real radio enjoyment, tune in the "Eveready Group," Broadcast through
WEAF New York
WJAR Providence
WEEI Boston
WFI Philadelphia
WGR Buffalo
WCAE Pittsburgh
WEAR Cleveland
WSAI Cincinnati
WWJ Detroit
WCCO { Minneapolis
 { St. Paul
WOC Davenport

PREFERRED

It is no accident that more Eveready Radio Batteries are purchased by the radio public than any other radio batteries.

Such complete and voluntary endorsement can lead to but one conclusion—for best reception and longest life, Eveready Radio Batteries lead the field.

You can prove this for yourself by hooking Eveready Radio Batteries to your set. You will find that they deliver a steady, vigorous stream of power that lasts longer. It is Eveready economy that has created such an overwhelming preference for Evereadys. There is an Eveready dealer nearby.

Manufactured and guaranteed by

NATIONAL CARBON COMPANY, INC.
New York San Francisco

Canadian National Carbon Co., Limited
Toronto, Ontario

EVEREADY Radio Batteries

-they last longer



No. 772
45-volt
Large
Vertical
Price
\$3.75



No. 767
45-volt
Large
Horizontal
Price
\$3.75
With
variable
taps

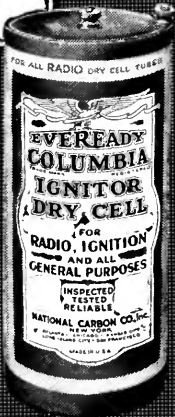

Eveready
Columbia
Ignitor
"A" Battery
The
proven
dry cell
for all
radio
dry cell
tubes
1½
volts

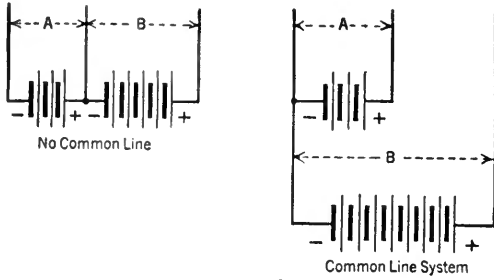

FIG. 6

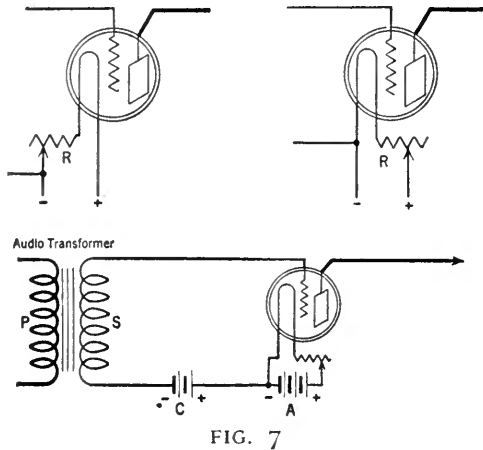

FIG. 7

difficult for the receiving station to pick up the wave of the transmitter.

In Fig. 4 the coils A, B and C comprise a standard vario-coupler redesigned as to winding in the manner shown in Fig. 5. The coil A consists of 50 turns of No. 18 d. c. c. wire, B 10 turns of the same wire and C 36 to 40 turns of any size wire from No's. 26 to 18. It will be necessary to experiment with the exact number of turns for C so that smooth control of regeneration is obtained over the entire wavelength band. Tuning is controlled by the variable condenser in series with the antenna. Its capacity rating is .001 mfd. With the key in the position shown, the circuit operates as a receiver but when the key is depressed it opens the phone circuit, closes the plate circuit and operates the apparatus as a transmitter.

Undoubtedly with the advent of the recent activity in short wave transmission this circuit will prove exceedingly interesting for experimentation.

NEEDED REFORM IN RADIO STANDARD PRACTISE

WITH something like 250 manufactured sets gracing the radio market and easily a like number of circuits for home construction, the need for standardization of circuit and connection methods becomes appallingly imperative. The question of A and B battery connections is only one of many but is the main subject of this discourse.

Many of the present circuits connect the plus A and B battery negative terminals together. Aside from

adding a few more plate volts potential in the plate circuit, there is no other reason for this special method of connection. It is not an advantage and is decidedly a disadvantage for the following reason.

First, it is an electrical common practise to have a power circuit with part of it at ground potential. At least there is a common lead which serves as a base for meter reading.

Obviously it is impossible to make the positive leads (for instance of A and B batteries) common, so the most natural thing and advantageous method would be to make the negative sides common. See Fig. 6. This system would greatly facilitate meter reading of A and B potentials by merely flipping a switch. It would also make the reading of circuit diagrams easier.

Another desirable point of standardization lies in the placement of rheostats. Tube manufactur-

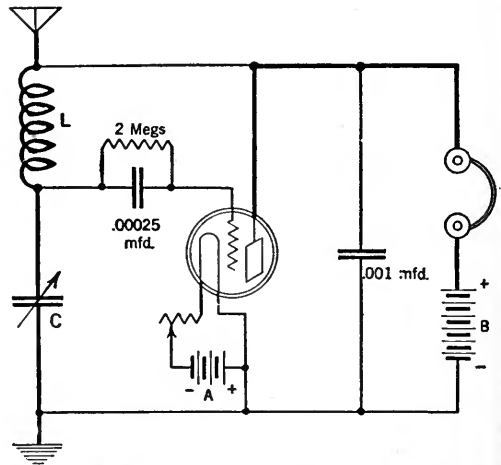

600 Meter Traffic	L = 100 to 150 Turn Honeycomb Coil
1200 - 2600 λ	" L = 300 to 400 " " "
2600 - 5000 λ	" L = 750 " " "
5000 - 15000 λ	" L = 1500 " " "

FIG. 8

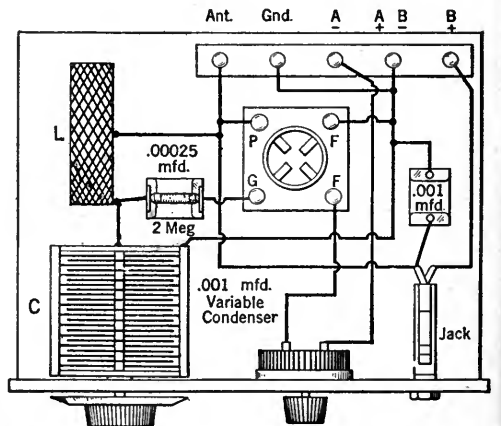

FIG. 9

? ? ? ? ? ? ? ? ? ? ? ? ? ?

YOU ARE PLANNING to build a radio receiver and you want to know what kind to make. Shall it be a one-tube reflex, or a four-tube ultra-sensitive tuned and neutralized radio-frequency receiver using regeneration and push-pull amplification? The book which will satisfy the needs of every radio constructor, **RADIO BROADCAST'S KNOCK-OUT RECEIVERS**, contains instructions on how to build these—in fact it tells how to make eight separate receivers.

EVERY PURSE and every desire is satisfied in the collection of receivers described in this book. Each one of the receivers was developed through the coöperation of **RADIO BROADCAST**, and thousands of radio enthusiasts all over the country have built these sets with the greatest of satisfaction.

THERE IS NO BETTER group of receivers from which to pick the type to build than those contained in **RADIO BROADCAST'S KNOCK-OUT RECEIVERS** because they have been designed by experts to fit the need of the broadcast listener. All of them can be built from standard parts.

COMPLETE INFORMATION is contained in the book (which has one hundred pages), for building these receivers, but no blue prints can be sold with it. Well known radio authors like Walter Van B. Roberts, Zeh Bouck, Kenneth Harkness, John B. Brennan, and others have written the descriptions. This book is now being printed and deliveries will be made at once. It will be sent to any address on receipt of \$1.00.

DOUBLEDAY, PAGE & COMPANY,
GARDEN CITY, NEW YORK

Please find enclosed \$1.00 for **RADIO BROADCAST'S KNOCK-OUT RECEIVERS** to be sent to

NAME

ADDRESS

RBA

ers advise placing a rheostat in the negative side of the filament supply so that a negative grid bias may be obtained.

With the use of C batteries for biasing there is no reason for not placing the rheostat in the positive lead which is the more practicable. See Fig. 7.

CODE INSTRUCTION

FOR learning the code by one's self there is nothing better than memorizing the characters and then listening-in on long wave transmission. And the surprising thing about it is that it can be done with a single tube. The American Radio Relay League's publication, QST, outlines in its March and June, 1925, issues a receiver satisfactory for just such purposes.

With a single honeycomb coil, variable condenser,

tube, socket, rheostat and batteries (antenna and ground also) it is possible to listen in on NSS, Annapolis, 17,000 meters; YN, Lyons, France, on 15,100 meters; KET, Bolinas, California on 13,345, and so on down the scale.

Some of these stations transmit slowly, repeating each word so that after one becomes proficient here he may jump down to the faster lanes of ship to shore traffic.

The circuit of the receiver is shown in Fig. 8 and the layout of the parts in Fig. 9. A 1-inch board 8 inches wide and 12 inches long is suitable. A panel 7 inches high and 12 inches long allows for the mounting of the condenser, rheostat and jack. Wire with bus wire for permanency. For additional information on this receiver it is well to consult the issues of QST mentioned above.

Before You Write to the Grid

THOUSANDS of you are writing the Grid for technical advice every month. The expense of framing a complete and exhaustive reply to each letter is very high. The editors have decided that the benefit of the questions and answers service will continue to be extended to regular subscribers, but that non-subscribers will be charged a fee of \$1 for each letter of inquiry which they send to our technical department. Very frequently, our technical information service proves of definite money value to you who write us, for we are often able by a sentence or two of explanation, to put you on the right path before you have made a perhaps expensive mistake.

The occasional reader of RADIO BROADCAST will be charged a fee of \$1 for complete reply to his questions, and the regular subscriber can continue to take advantage of the service as before. In that way the non-subscriber will help share the cost of the technical staff whose service he gets. Every letter receives the benefit of the experience of the editor and the technical staff and every correspondent may be sure that his questions will receive careful consideration and reply.

When writing to the Grid, please use the blank printed below.

GRID INQUIRY BLANK

Editor, The Grid,
RADIO BROADCAST,
Garden City, New York.

Dear Sir:

Attached please find a sheet containing questions upon which kindly give me fullest possible information. I enclose a stamped return envelope.

(Check the proper square)

- I am a subscriber to RADIO BROADCAST. Information is to be supplied to me free of charge.
- I am not a subscriber. I enclose \$1 to cover costs of a letter answering my questions.

My name is _____

My address is _____

G. A.



It isn't a
genuine
 UV-199
 unless
 it's a
Radiotron

The familiar names
 WD-11, WD-12,
 UV-199, UV-200
 and UV-201-A
 rightfully belong
 to *Radiotrons*
 only. To be sure of
 quality, it is im-
 portant to look care-
 fully at the base of
 every tube you buy
 to see that it carries
 the name *Radiot-
 ron* and the RCA
 mark as proof that
 it is a *genuine*
Radiotron.



Radio Corporation of America

Chicago

New York

San Francisco



Radiotron

AN RCA PRODUCT



WHERE RADIO IS NOT SIMPLY "FURNITURE"

A farmer's home in central Iowa, where the radio receiver is a vital part of the home equipment. Farmers have found market reports a direct financial help to them during the daylight hours. In the evening the farmers are some of the most interested of broadcast listeners. Radio is helping to solve the problem of how to keep the farmers on the farm